

- 27: Cyc
- 26: 2G | Tree Silhouette
- 25: Black Scrim
- 24: 2G | Blackout + 14' Hole
- 23: 2G | Sheer Curtains
- 22: #4 Electric
- 21: 2G | Ring B
- 20: Legs
- 19: Teaser
- 18: Lear | Paper Cyc on Traveller
- 17: Lear | Beam #3
- 16: #3 Electric
- 15: Lear | Slats
- 14: Lear | 6 Posts
- 13: Legs
- 12: Teaser
- 11: x
- 10: #2 Electric
- 9: Lear | Beam #2
- 8: Lear | Spear Wall
- 7: x (shell storage)
- 6: 2G | Ring A
- 5: x (shell storage)
- 4: #1 Electric
- 3: Legs
- 2: Teaser
- 1: Lear | Beam #1 + 2G | Top of Act Signs (hung below the main curtain)

Notes:
 All borders are @ 17'-8" to theatre floor
 Shells are currently stored on #s 7, 13, 18, 23

- Drawing List:**
- 1a LEAR: Ground Plan
 - 1b 2G: Ground Plan
 - 1c CW: Ground Plan
 - 1d Composite Ground Plan
 - 2a LEAR: Centerline Section
 - 2b 2G: Centerline Section
 - 2c CW: Centerline Section
 - 2d Composite Centerline Section
 - 3 Season Platform
 - 4 LEAR: Post, Pole Arms
 - 5 LEAR: 6 Posts, Slats
 - 6 LEAR: Paper Cyc
 - 7 LEAR: Throne & Other Pieces
 - 8 2G: Platforms
 - 9 2G: Fountain & Bench
 - 10 2G: Circles
 - 11 2G: Banners
 - 12 CW: Walls

KING LEAR great river shakespeare festival '12
 composite ground plan | 4.10.12 | 1/2" = 1'-0"
 James edmondson, director | r. eric stone, scenic designer | tom koder, technical director

top of show
 plate **1A**

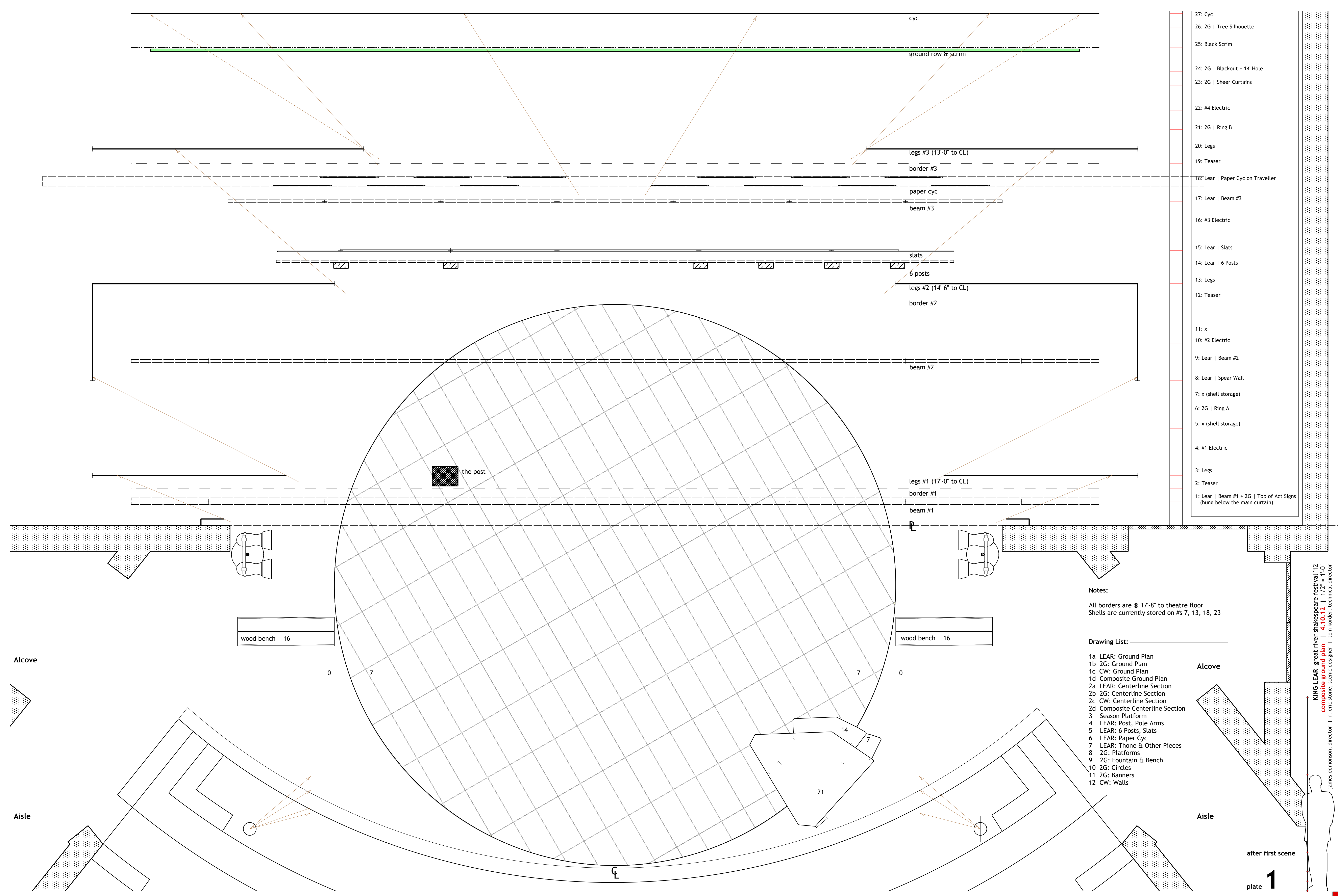

- 27: Cyc
- 26: 2G | Tree Silhouette
- 25: Black Scrim
- 24: 2G | Blackout + 14' Hole
- 23: 2G | Sheer Curtains
- 22: #4 Electric
- 21: 2G | Ring B
- 20: Legs
- 19: Teaser
- 18: Lear | Paper Cyc on Traveller
- 17: Lear | Beam #3
- 16: #3 Electric
- 15: Lear | Slats
- 14: Lear | 6 Posts
- 13: Legs
- 12: Teaser
- 11: x
- 10: #2 Electric
- 9: Lear | Beam #2
- 8: Lear | Spear Wall
- 7: x (shell storage)
- 6: 2G | Ring A
- 5: x (shell storage)
- 4: #1 Electric
- 3: Legs
- 2: Teaser
- 1: Lear | Beam #1 + 2G | Top of Act Signs (hung below the main curtain)

Notes:
 All borders are @ 17'-8" to theatre floor
 Shells are currently stored on #s 7, 13, 18, 23

- Drawing List:**
- 1a LEAR: Ground Plan
 - 1b 2G: Ground Plan
 - 1c CW: Ground Plan
 - 1d Composite Ground Plan
 - 2a LEAR: Centerline Section
 - 2b 2G: Centerline Section
 - 2c CW: Centerline Section
 - 2d Composite Centerline Section
 - 3 Season Platform
 - 4 LEAR: Post, Pole Arms
 - 5 LEAR: 6 Posts, Slats
 - 6 LEAR: Paper Cyc
 - 7 LEAR: Thone & Other Pieces
 - 8 2G: Platforms
 - 9 2G: Fountain & Bench
 - 10 2G: Circles
 - 11 2G: Banners
 - 12 CW: Walls

KING LEAR great river shakespeare festival '12
 composite ground plan | 4.10.12 | 1/2" = 1'-0"
 James edmondson, director | r. eric stone, scenic designer | tom koder, technical director

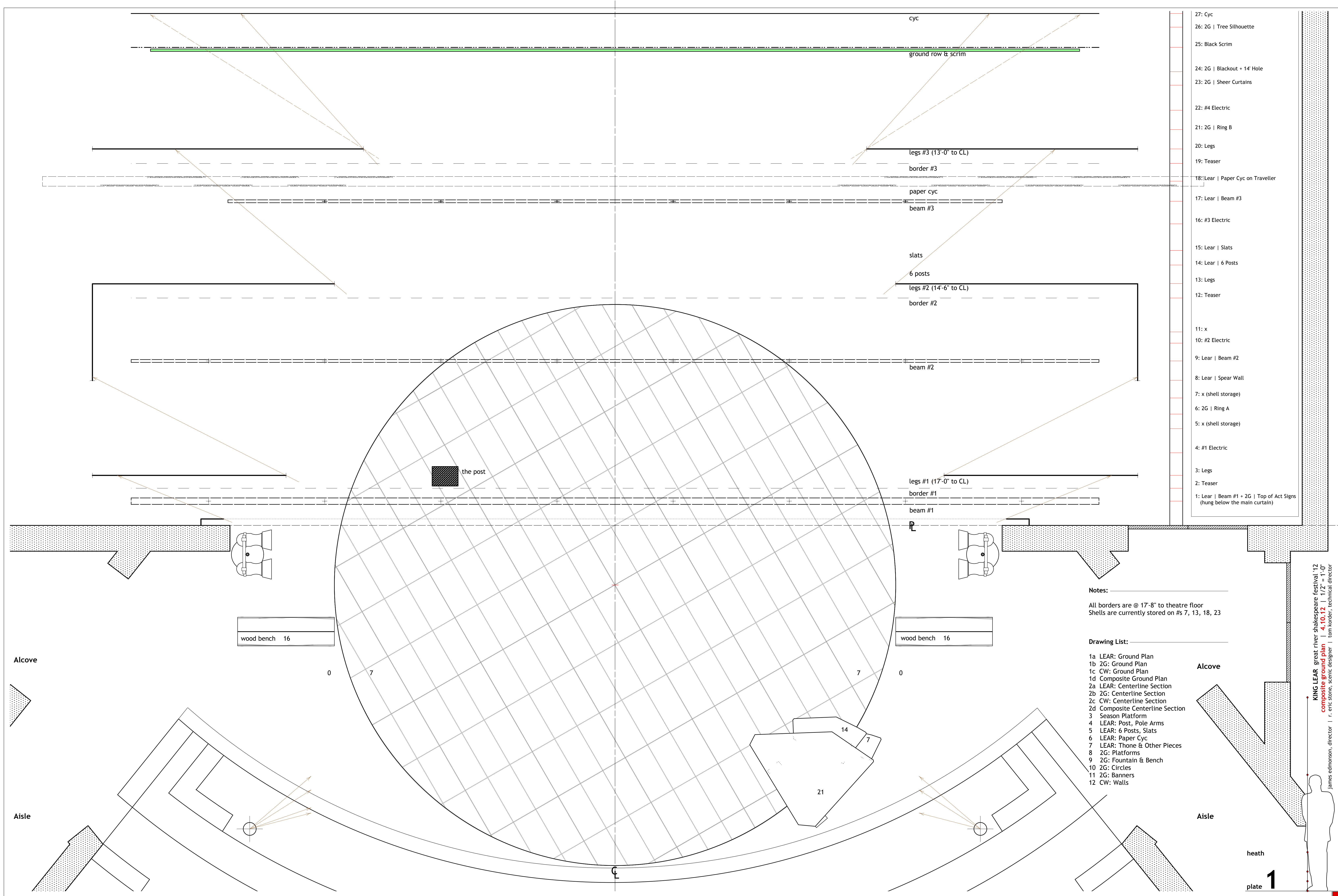

- 27: Cyc
- 26: 2G | Tree Silhouette
- 25: Black Scrim
- 24: 2G | Blackout + 14' Hole
- 23: 2G | Sheer Curtains
- 22: #4 Electric
- 21: 2G | Ring B
- 20: Legs
- 19: Teaser
- 18: Lear | Paper Cyc on Traveller
- 17: Lear | Beam #3
- 16: #3 Electric
- 15: Lear | Slats
- 14: Lear | 6 Posts
- 13: Legs
- 12: Teaser
- 11: x
- 10: #2 Electric
- 9: Lear | Beam #2
- 8: Lear | Spear Wall
- 7: x (shell storage)
- 6: 2G | Ring A
- 5: x (shell storage)
- 4: #1 Electric
- 3: Legs
- 2: Teaser
- 1: Lear | Beam #1 + 2G | Top of Act Signs (hung below the main curtain)

Notes:
 All borders are @ 17'-8" to theatre floor
 Shells are currently stored on #s 7, 13, 18, 23

- Drawing List:**
- 1a LEAR: Ground Plan
 - 1b 2G: Ground Plan
 - 1c CW: Ground Plan
 - 1d Composite Ground Plan
 - 2a LEAR: Centerline Section
 - 2b 2G: Centerline Section
 - 2c CW: Centerline Section
 - 2d Composite Centerline Section
 - 3 Season Platform
 - 4 LEAR: Post, Pole Arms
 - 5 LEAR: 6 Posts, Slats
 - 6 LEAR: Paper Cyc
 - 7 LEAR: Thone & Other Pieces
 - 8 2G: Platforms
 - 9 2G: Fountain & Bench
 - 10 2G: Circles
 - 11 2G: Banners
 - 12 CW: Walls

KING LEAR great river shakespeare festival '12
 composite ground plan | 4, 10, 12 | 1/2" = 1'-0"
 James edmondson, director | r. eric stone, scenic designer | tom koder, technical director

heath
 plate **1**

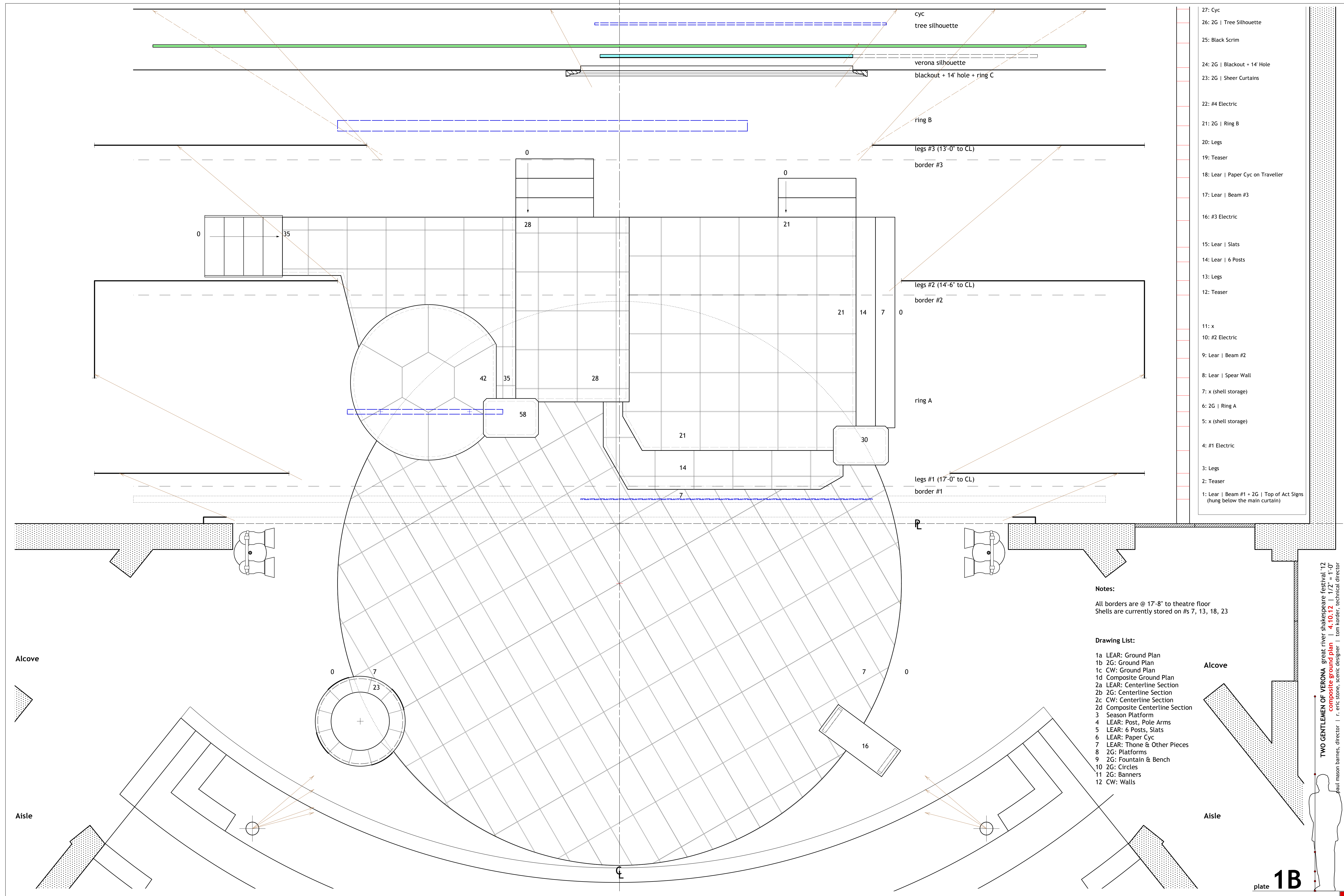

- 27: Cyc
- 26: 2G | Tree Silhouette
- 25: Black Scrim
- 24: 2G | Blackout + 14' Hole
- 23: 2G | Sheer Curtains
- 22: #4 Electric
- 21: 2G | Ring B
- 20: Legs
- 19: Teaser
- 18: Lear | Paper Cyc on Traveller
- 17: Lear | Beam #3
- 16: #3 Electric
- 15: Lear | Slats
- 14: Lear | 6 Posts
- 13: Legs
- 12: Teaser
- 11: x
- 10: #2 Electric
- 9: Lear | Beam #2
- 8: Lear | Spear Wall
- 7: x (shell storage)
- 6: 2G | Ring A
- 5: x (shell storage)
- 4: #1 Electric
- 3: Legs
- 2: Teaser
- 1: Lear | Beam #1 + 2G | Top of Act Signs (hung below the main curtain)

Notes:
 All borders are @ 17'-8" to theatre floor
 Shells are currently stored on #s 7, 13, 18, 23

- Drawing List:**
- 1a LEAR: Ground Plan
 - 1b 2G: Ground Plan
 - 1c CW: Ground Plan
 - 1d Composite Ground Plan
 - 2a LEAR: Centerline Section
 - 2b 2G: Centerline Section
 - 2c CW: Centerline Section
 - 2d Composite Centerline Section
 - 3 Season Platform
 - 4 LEAR: Post, Pole Arms
 - 5 LEAR: 6 Posts, Slats
 - 6 LEAR: Paper Cyc
 - 7 LEAR: Thone & Other Pieces
 - 8 2G: Platforms
 - 9 2G: Fountain & Bench
 - 10 2G: Circles
 - 11 2G: Banners
 - 12 CW: Walls

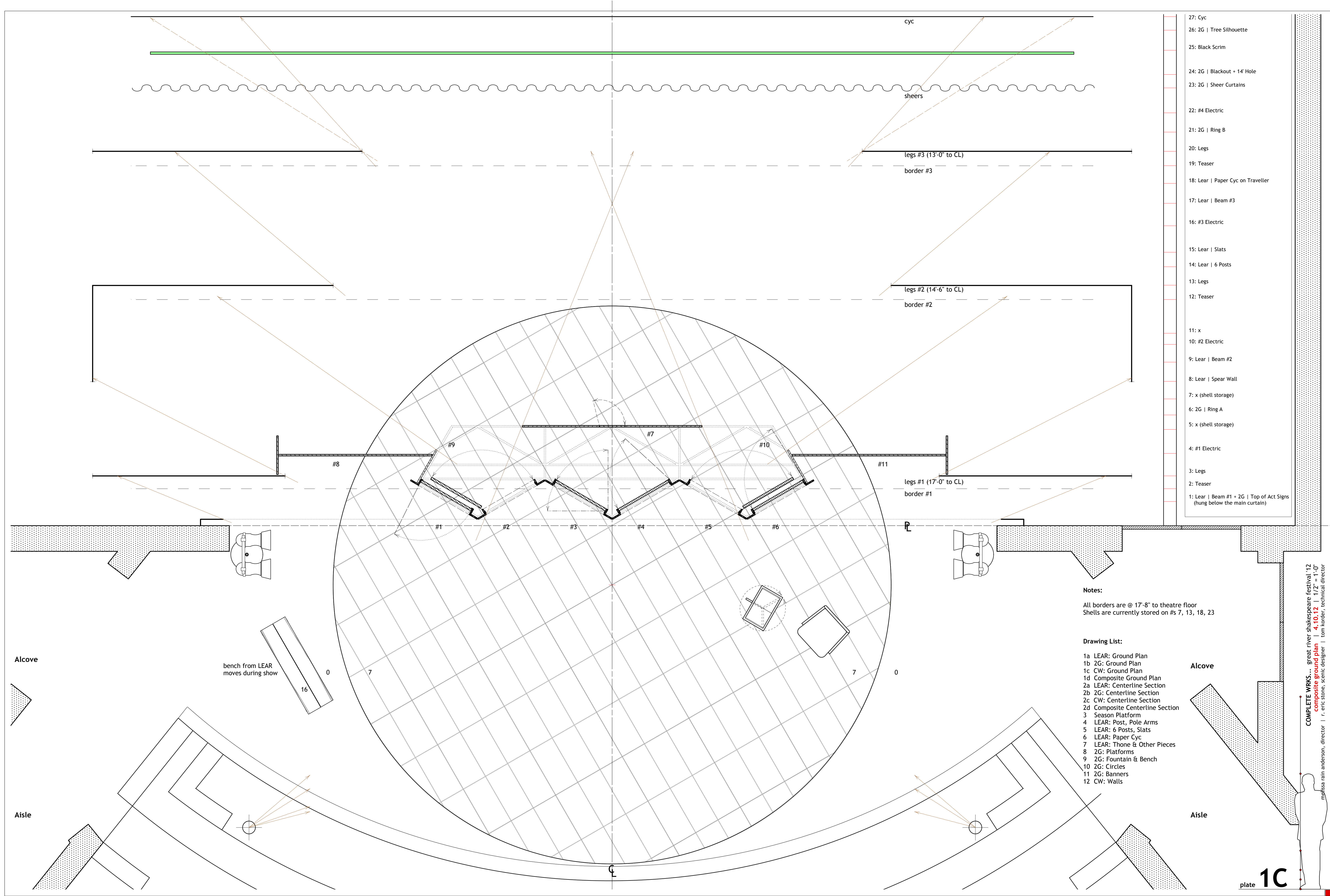

- 27: Cyc
- 26: 2G | Tree Silhouette
- 25: Black Scrim
- 24: 2G | Blackout + 14' Hole
- 23: 2G | Sheer Curtains
- 22: #4 Electric
- 21: 2G | Ring B
- 20: Legs
- 19: Teaser
- 18: Lear | Paper Cyc on Traveller
- 17: Lear | Beam #3
- 16: #3 Electric
- 15: Lear | Slats
- 14: Lear | 6 Posts
- 13: Legs
- 12: Teaser
- 11: x
- 10: #2 Electric
- 9: Lear | Beam #2
- 8: Lear | Spear Wall
- 7: x (shell storage)
- 6: 2G | Ring A
- 5: x (shell storage)
- 4: #1 Electric
- 3: Legs
- 2: Teaser
- 1: Lear | Beam #1 + 2G | Top of Act Signs (hung below the main curtain)

Notes:
 All borders are @ 17'-8" to theatre floor
 Shells are currently stored on # 7, 13, 18, 23

- Drawing List:**
- 1a LEAR: Ground Plan
 - 1b 2G: Ground Plan
 - 1c CW: Ground Plan
 - 1d Composite Ground Plan
 - 2a LEAR: Centerline Section
 - 2b 2G: Centerline Section
 - 2c CW: Centerline Section
 - 2d Composite Centerline Section
 - 3 Season Platform
 - 4 LEAR: Post, Pole Arms
 - 5 LEAR: 6 Posts, Slats
 - 6 LEAR: Paper Cyc
 - 7 LEAR: Thone & Other Pieces
 - 8 2G: Platforms
 - 9 2G: Fountain & Bench
 - 10 2G: Circles
 - 11 2G: Banners
 - 12 CW: Walls

COMPLETE WRKS... great river shakespeare festival '12
 composite ground plan | 4.10.12 | 1/2" = 1'-0"
 melissa rain anderson, director | r. eric stone, scenic designer | tom korder, technical director

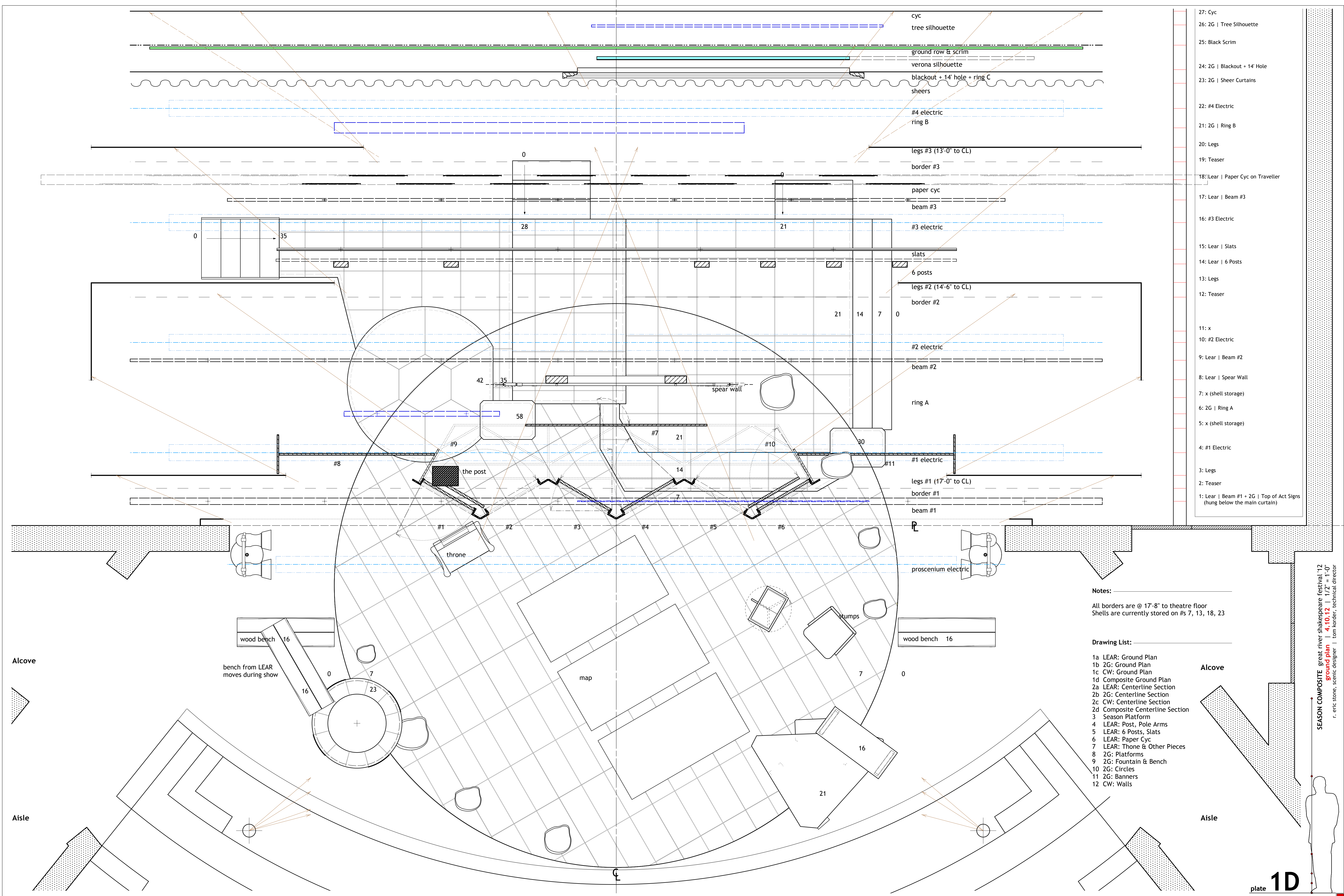

- 27: Cyc
- 26: 2G | Tree Silhouette
- 25: Black Scrim
- 24: 2G | Blackout + 14' Hole
- 23: 2G | Sheer Curtains
- 22: #4 Electric
- 21: 2G | Ring B
- 20: Legs
- 19: Teaser
- 18: Lear | Paper Cyc on Traveller
- 17: Lear | Beam #3
- 16: #3 Electric
- 15: Lear | Slats
- 14: Lear | 6 Posts
- 13: Legs
- 12: Teaser
- 11: x
- 10: #2 Electric
- 9: Lear | Beam #2
- 8: Lear | Spear Wall
- 7: x (shell storage)
- 6: 2G | Ring A
- 5: x (shell storage)
- 4: #1 Electric
- 3: Legs
- 2: Teaser
- 1: Lear | Beam #1 + 2G | Top of Act Signs (hung below the main curtain)

Notes:

All borders are @ 17'-8" to theatre floor
 Shells are currently stored on #s 7, 13, 18, 23

- Drawing List:**
- 1a LEAR: Ground Plan
 - 1b 2G: Ground Plan
 - 1c CW: Ground Plan
 - 1d Composite Ground Plan
 - 2a LEAR: Centerline Section
 - 2b 2G: Centerline Section
 - 2c CW: Centerline Section
 - 2d Composite Centerline Section
 - 3 Season Platform
 - 4 LEAR: Post, Pole Arms
 - 5 LEAR: 6 Posts, Slats
 - 6 LEAR: Paper Cyc
 - 7 LEAR: Throne & Other Pieces
 - 8 2G: Platforms
 - 9 2G: Fountain & Bench
 - 10 2G: Circles
 - 11 2G: Banners
 - 12 CW: Walls

SEASON COMPOSITE great river shakespeare festival '12
 ground plan 4.10.12 | 1/2" = 1'-0"
 r. eric stone, scenic designer | tom korder, technical director

All borders are @ 17'-8" to theatre floor.
 Confirm border & leg inventory (height/width)
 Confirm dimensions of cyc & scrim

- 30: Cyc Electric
- 29: x (shell storage)
- 28: x (shell storage)
- 27: Cyc
- 26: 2G | Tree Silhouette
- 25: Black Scrim
- 24: 2G | Blackout + 14 Hole
- 23: 2G | Sheer Curtains
- 22: #4 Electric
- 21: 2G | Ring B
- 20: Legs
- 19: Teaser
- 18: Lear | Paper Cyc on Traveller
- 17: Lear | Beam #3
- 16: #3 Electric
- 15: Lear | Slats
- 14: Lear | 6 Posts
- 13: Legs
- 12: Teaser
- 11: x
- 10: #2 Electric
- 9: Lear | Beam #2
- 8: Lear | Spear Wall
- 7: x (shell storage)
- 6: 2G | Ring A
- 5: x (shell storage)
- 4: #1 Electric
- 3: Legs
- 2: Teaser
- 1: Lear | Beam #1 + 2G | Top of Act Signs (hung below the main curtain)

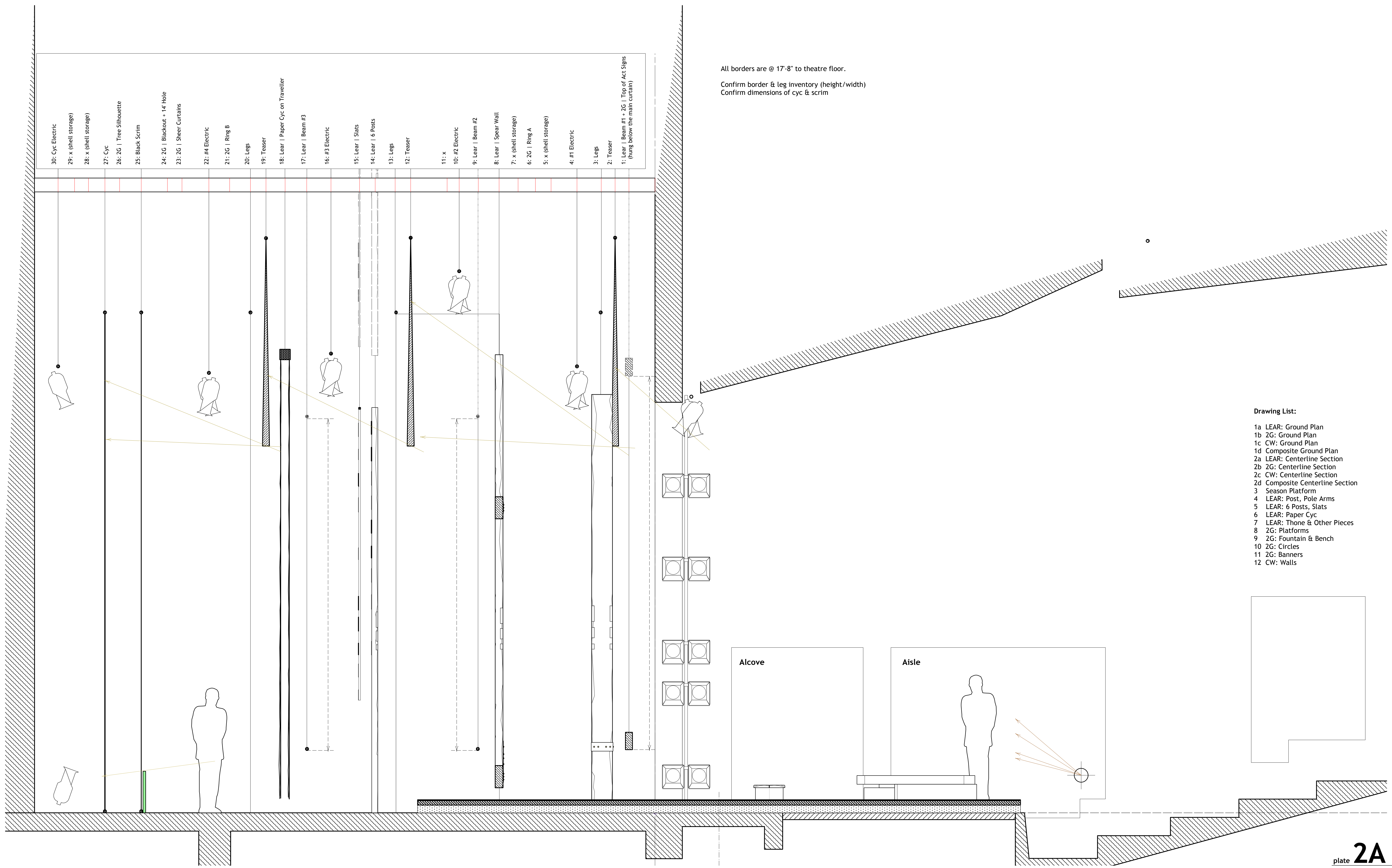

- Drawing List:**
- 1a LEAR: Ground Plan
 - 1b 2G: Ground Plan
 - 1c CW: Ground Plan
 - 1d Composite Ground Plan
 - 2a LEAR: Centerline Section
 - 2b 2G: Centerline Section
 - 2c CW: Centerline Section
 - 2d Composite Centerline Section
 - 3 Season Platform
 - 4 LEAR: Post, Pole Arms
 - 5 LEAR: 6 Posts, Slats
 - 6 LEAR: Paper Cyc
 - 7 LEAR: Thone & Other Pieces
 - 8 2G: Platforms
 - 9 2G: Fountain & Bench
 - 10 2G: Circles
 - 11 2G: Banners
 - 12 CW: Walls

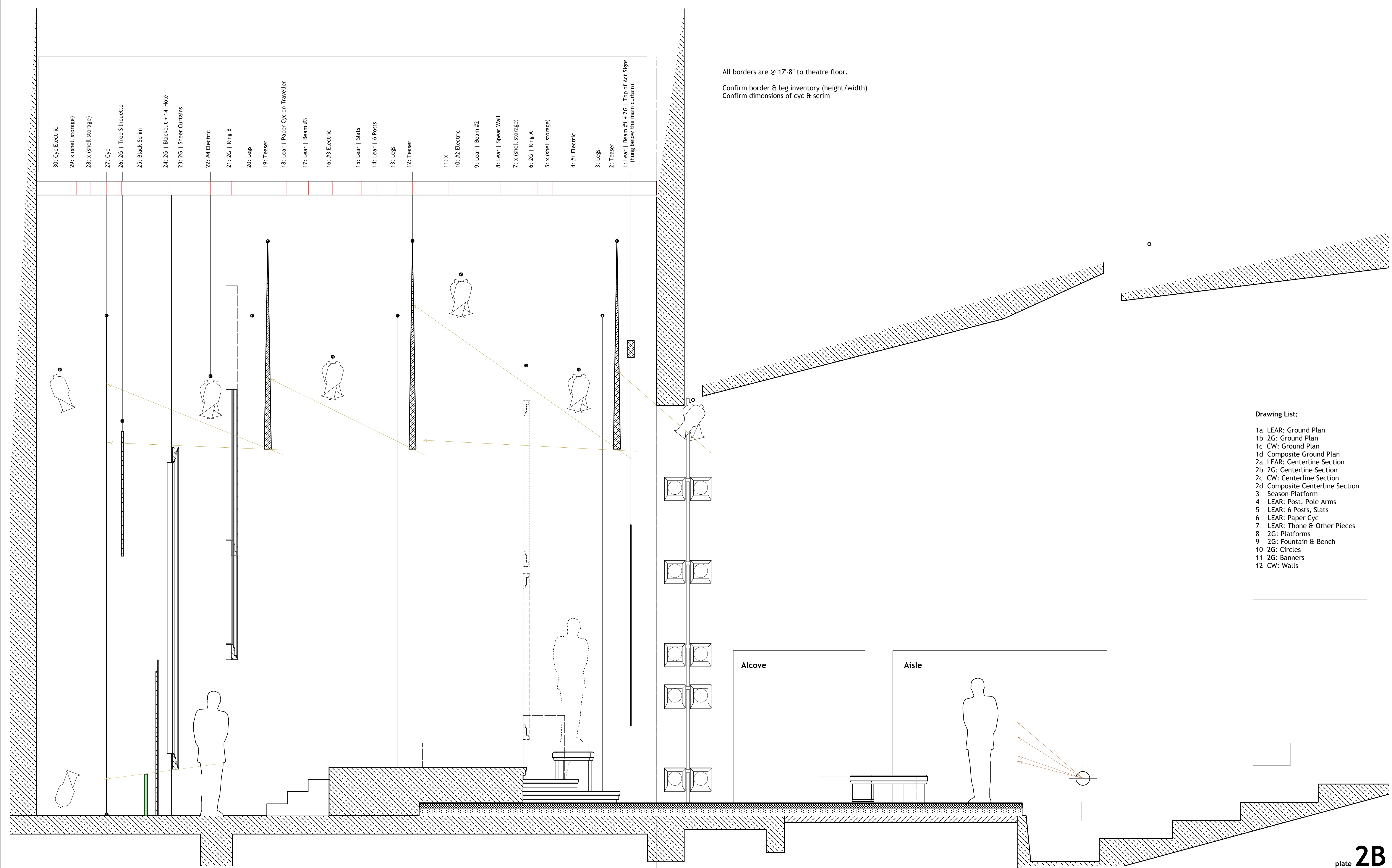

All borders are @ 17'-8" to theatre floor.
 Confirm border & leg inventory (height/width)
 Confirm dimensions of cyc & scrim

- 30: Cyc Electric
- 29: x (shell storage)
- 28: x (shell storage)
- 27: Cyc
- 26: 2G | Tree Silhouette
- 25: Black Scrim
- 24: 2G | Blackout + 14' Hole
- 23: 2G | Sheer Curtains
- 22: #4 Electric
- 21: 2G | Ring B
- 20: Legs
- 19: Teaser
- 18: Lear | Paper Cyc on Traveller
- 17: Lear | Beam #3
- 16: #3 Electric
- 15: Lear | Slats
- 14: Lear | 6 Posts
- 13: Legs
- 12: Teaser
- 11: x
- 10: #2 Electric
- 9: Lear | Beam #2
- 8: Lear | Spear Wall
- 7: x (shell storage)
- 6: 2G | Ring A
- 5: x (shell storage)
- 4: #1 Electric
- 3: Legs
- 2: Teaser
- 1: Lear | Beam #1 + 2G | Top of Act Signs (hung below the main curtain)

- Drawing List:**
- 1a LEAR: Ground Plan
 - 1b 2G: Ground Plan
 - 1c CW: Ground Plan
 - 1d Composite Ground Plan
 - 2a LEAR: Centerline Section
 - 2b 2G: Centerline Section
 - 2c CW: Centerline Section
 - 2d Composite Centerline Section
 - 3 Season Platform
 - 4 LEAR: Post, Pole Arms
 - 5 LEAR: 6 Posts, Slats
 - 6 LEAR: Paper Cyc
 - 7 LEAR: Thone & Other Pieces
 - 8 2G: Platforms
 - 9 2G: Fountain & Bench
 - 10 2G: Circles
 - 11 2G: Banners
 - 12 CW: Walls

Alcove

Aisle

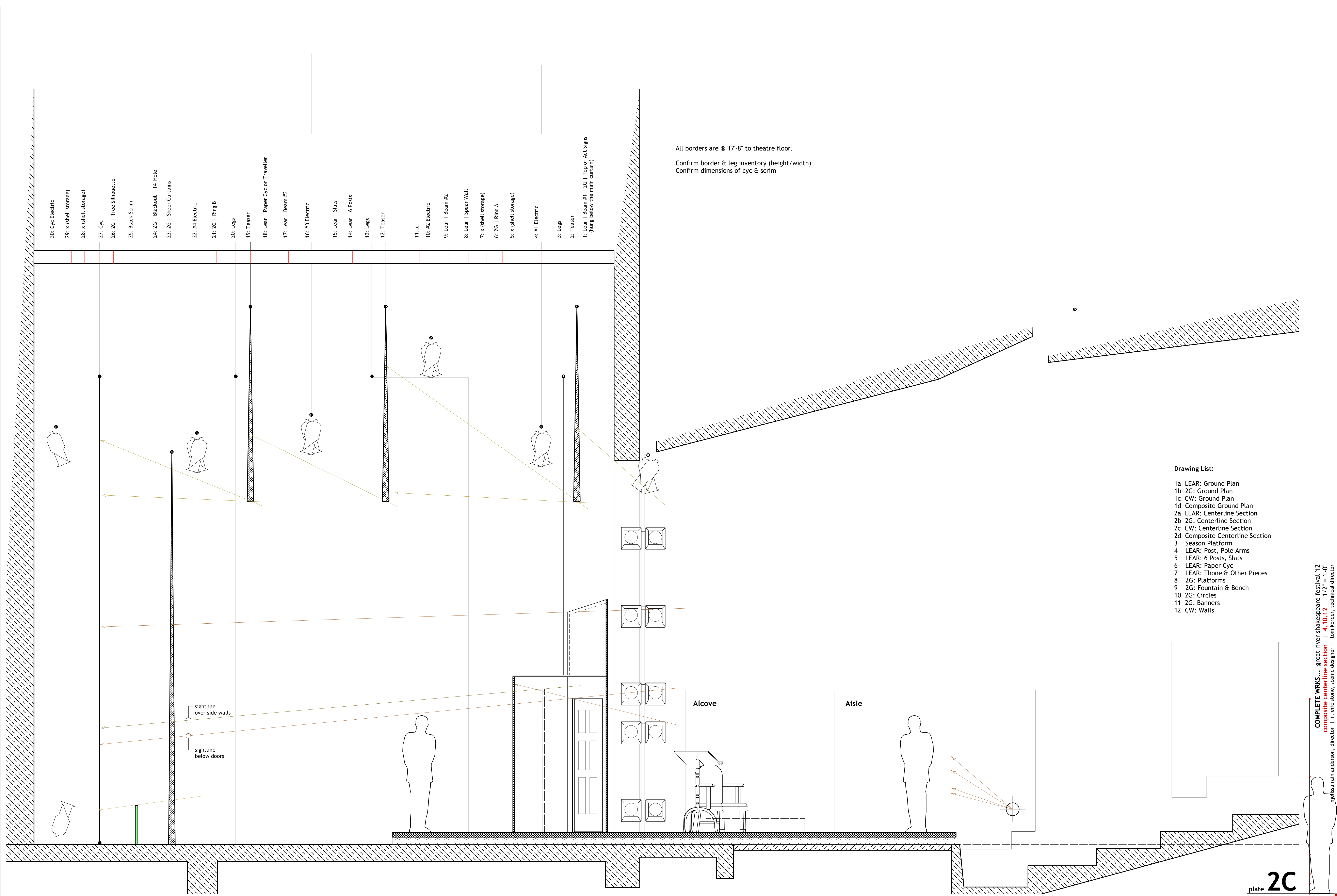

All borders are @ 17'-8" to theatre floor.
 Confirm border & leg inventory (height/width)
 Confirm dimensions of cyc & scrim

- 30: Cyc Electric
- 29: x (shell storage)
- 28: x (shell storage)
- 27: Cyc
- 26: 2G | Tree Silhouette
- 25: Black Scrim
- 24: 2G | Blackout + 14 Hole
- 23: 2G | Sheer Curtains
- 22: #4 Electric
- 21: 2G | Ring B
- 20: Legs
- 19: Teaser
- 18: Lear | Paper Cyc on Traveller
- 17: Lear | Beam #3
- 16: #3 Electric
- 15: Lear | Slats
- 14: Lear | 6 Posts
- 13: Legs
- 12: Teaser
- 11: x
- 10: #2 Electric
- 9: Lear | Beam #2
- 8: Lear | Spear Wall
- 7: x (shell storage)
- 6: 2G | Ring A
- 5: x (shell storage)
- 4: #1 Electric
- 3: Legs
- 2: Teaser
- 1: Lear | Beam #1 + 2G | Top of Act Signs (hang below the main curtain)

sightline over side walls

sightline below doors

- Drawing List:**
- 1a LEAR: Ground Plan
 - 1b 2G: Ground Plan
 - 1c CW: Ground Plan
 - 1d Composite Ground Plan
 - 2a LEAR: Centerline Section
 - 2b 2G: Centerline Section
 - 2c CW: Centerline Section
 - 2d Composite Centerline Section
 - 3 Season Platform
 - 4 LEAR: Post, Pole Arms
 - 5 LEAR: 6 Posts, Slats
 - 6 LEAR: Paper Cyc
 - 7 LEAR: Thone & Other Pieces
 - 8 2G: Platforms
 - 9 2G: Fountain & Bench
 - 10 2G: Circles
 - 11 2G: Banners
 - 12 CW: Walls

All borders are @ 17'-8" to theatre floor.
 Confirm border & leg inventory (height/width)
 Confirm dimensions of cyc & scrim

- 30: Cyc Electric
- 29: x (shell storage)
- 28: x (shell storage)
- 27: Cyc
- 26: 2G | Tree Silhouette
- 25: Black Scrim
- 24: 2G | Blackout + 14 Hole
- 23: 2G | Sheer Curtains
- 22: #4 Electric
- 21: 2G | Ring B
- 20: Legs
- 19: Teaser
- 18: Lear | Paper Cyc on Traveller
- 17: Lear | Beam #3
- 16: #3 Electric
- 15: Lear | Slats
- 14: Lear | 6 Posts
- 13: Legs
- 12: Teaser
- 11: x
- 10: #2 Electric
- 9: Lear | Beam #2
- 8: Lear | Spear Wall
- 7: x (shell storage)
- 6: 2G | Ring A
- 5: x (shell storage)
- 4: #1 Electric
- 3: Legs
- 2: Teaser
- 1: Lear | Beam #1 + 2G | Top of Act Signs (hung below the main curtain)

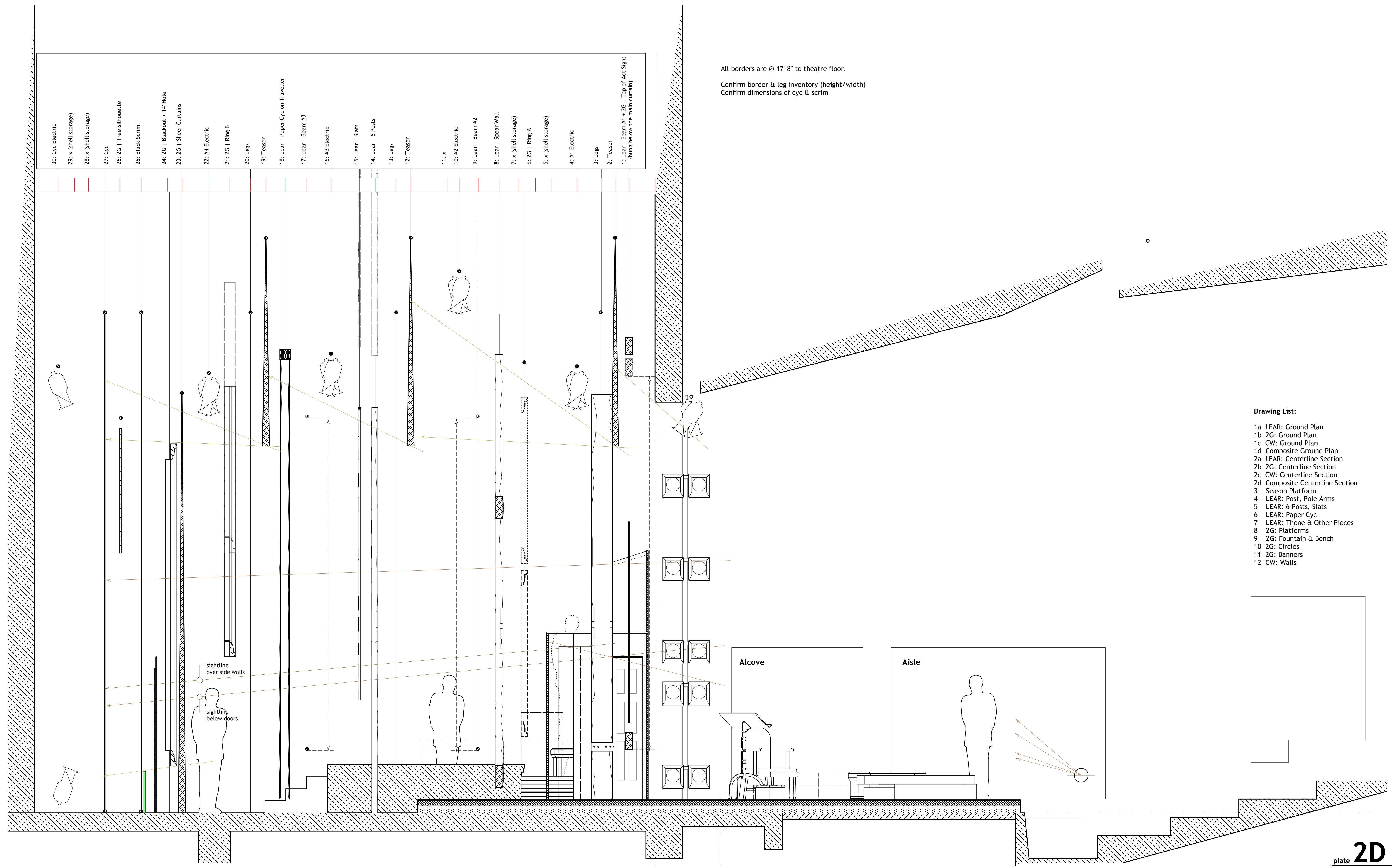

- Drawing List:
- 1a LEAR: Ground Plan
 - 1b 2G: Ground Plan
 - 1c CW: Ground Plan
 - 1d Composite Ground Plan
 - 2a LEAR: Centerline Section
 - 2b 2G: Centerline Section
 - 2c CW: Centerline Section
 - 2d Composite Centerline Section
 - 3 Season Platform
 - 4 LEAR: Post, Pole Arms
 - 5 LEAR: 6 Posts, Slats
 - 6 LEAR: Paper Cyc
 - 7 LEAR: Thone & Other Pieces
 - 8 2G: Platforms
 - 9 2G: Fountain & Bench
 - 10 2G: Circles
 - 11 2G: Banners
 - 12 CW: Walls

plate **2D**

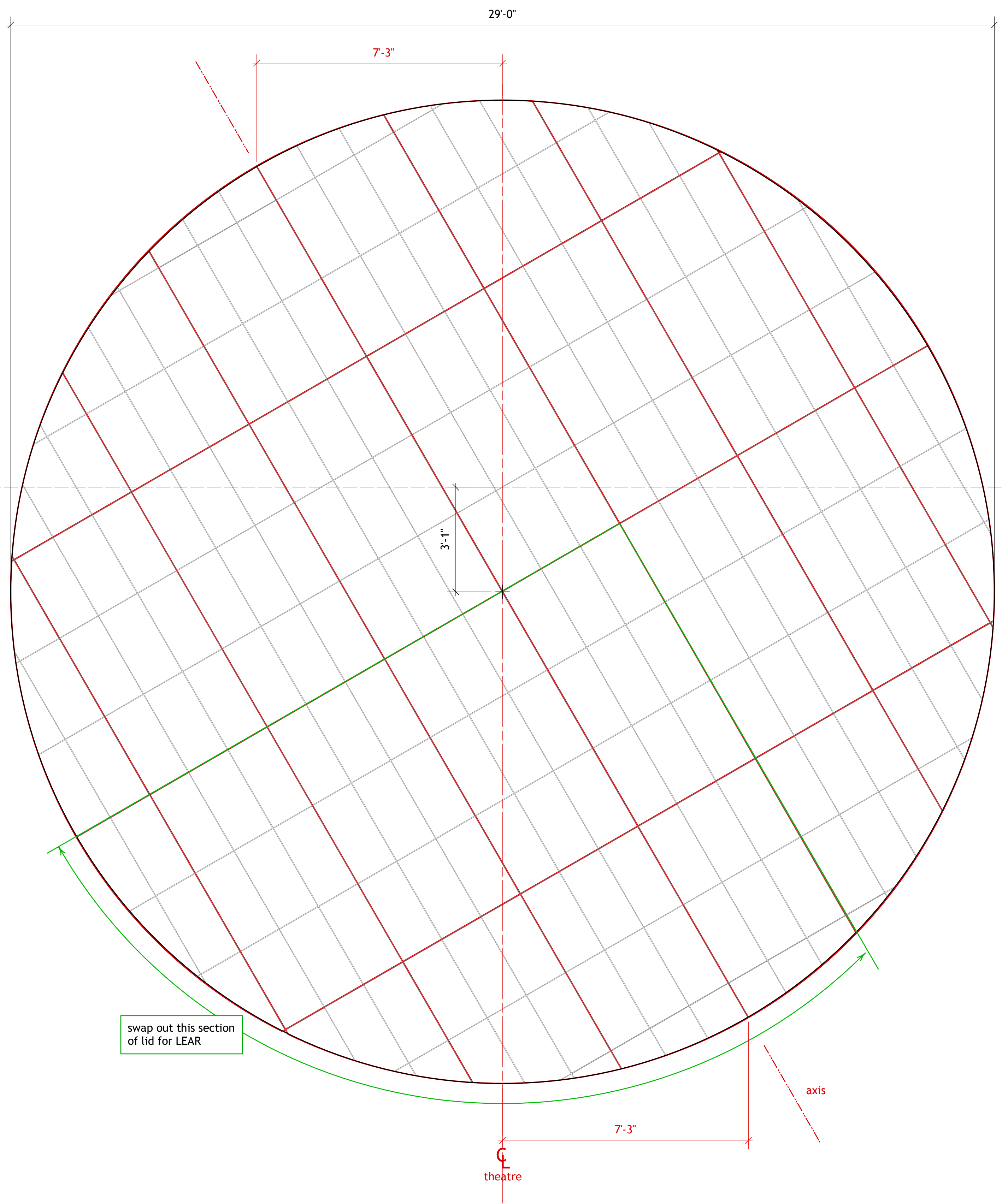

R

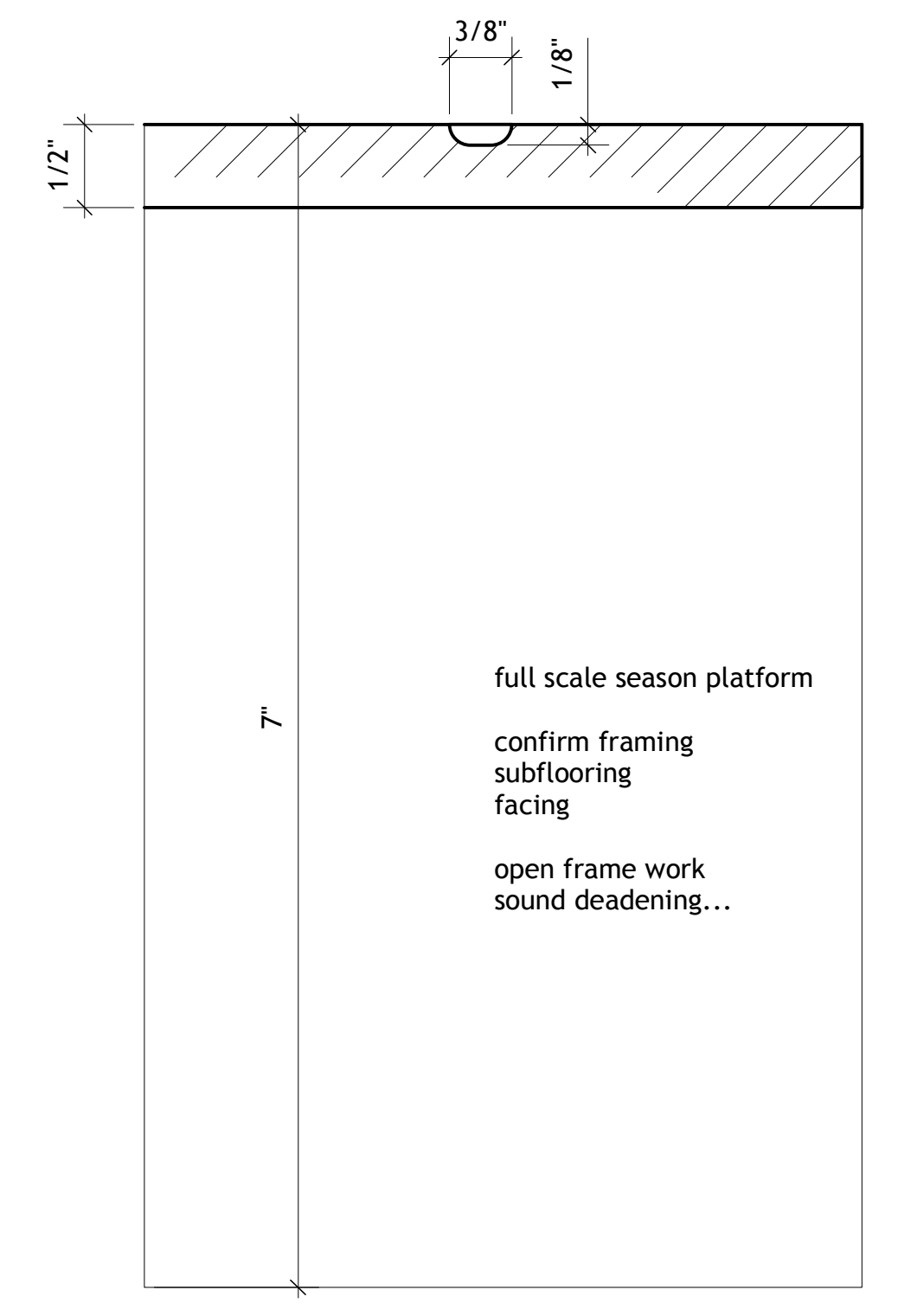
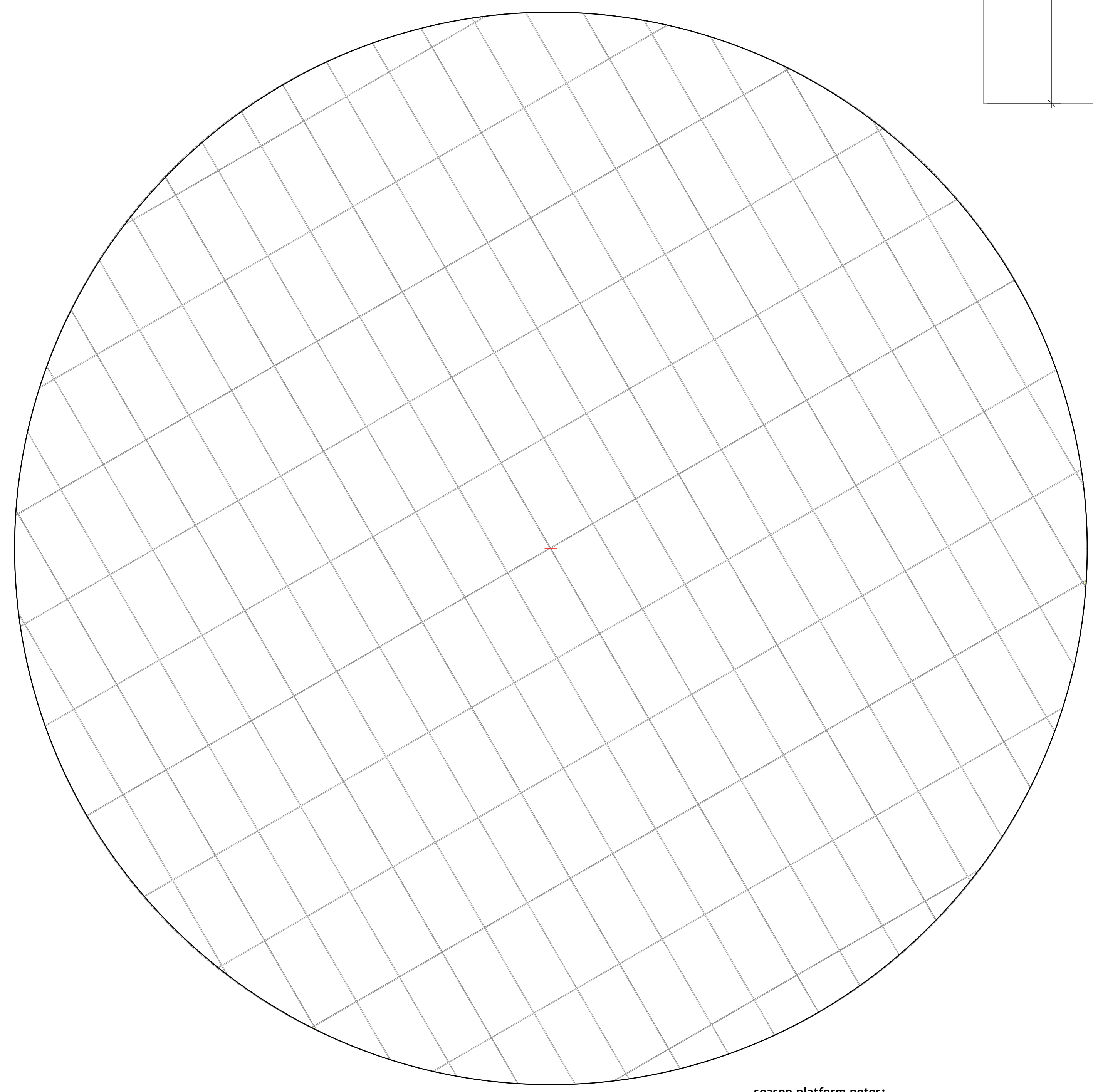

season platform notes:
 confirm overall height
 all show units drawn w/ a 7" total height of this platform
 4x 8' sheet stock layout
 axis is 60 degrees, relative to CL
 3/8" w x 1/8" rout into lid for tile patters
 bury screws into rout areas
 facing is open to season/platform truss work

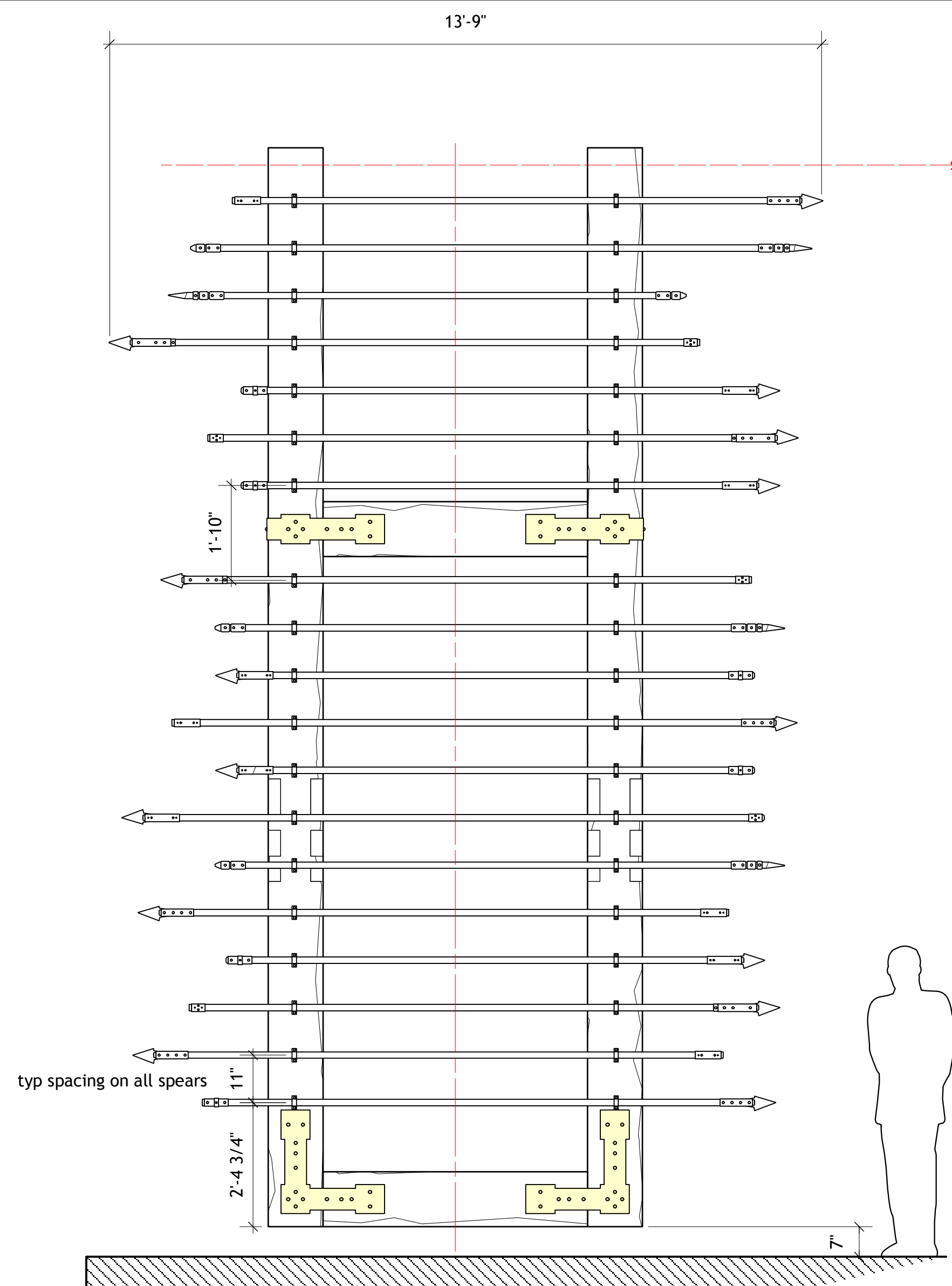

front view w/ spears

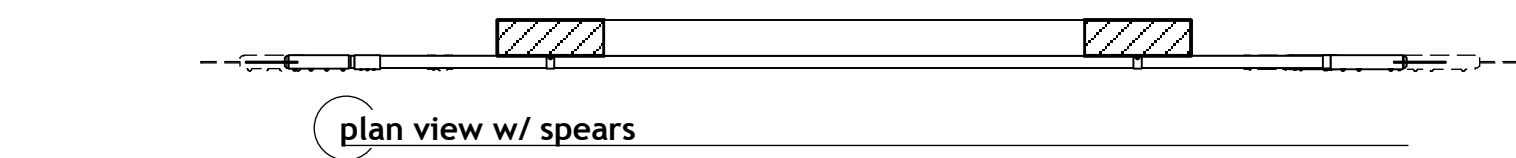

plan view w/ spears

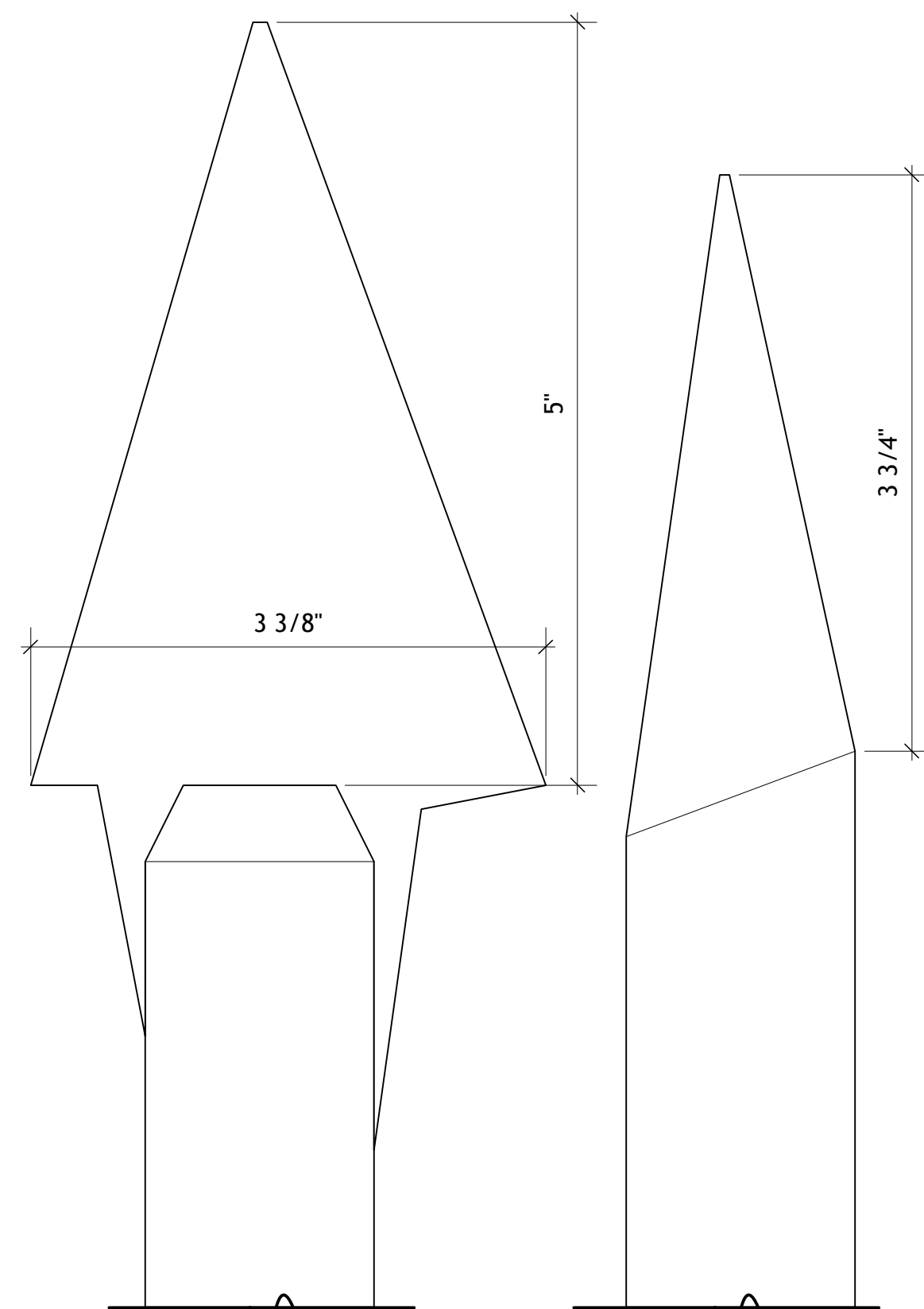

full scale pike w/ spear detail

full scale pike w/ point detail

POLE ARMS
 19 units
 poles are 1 1/2" dia
 ranging from 10' to 12' long
 see fsd for added embellishments
 anchor to posts w/ hanging bracket,
 confirm size/look w/ eric

CL section

side view

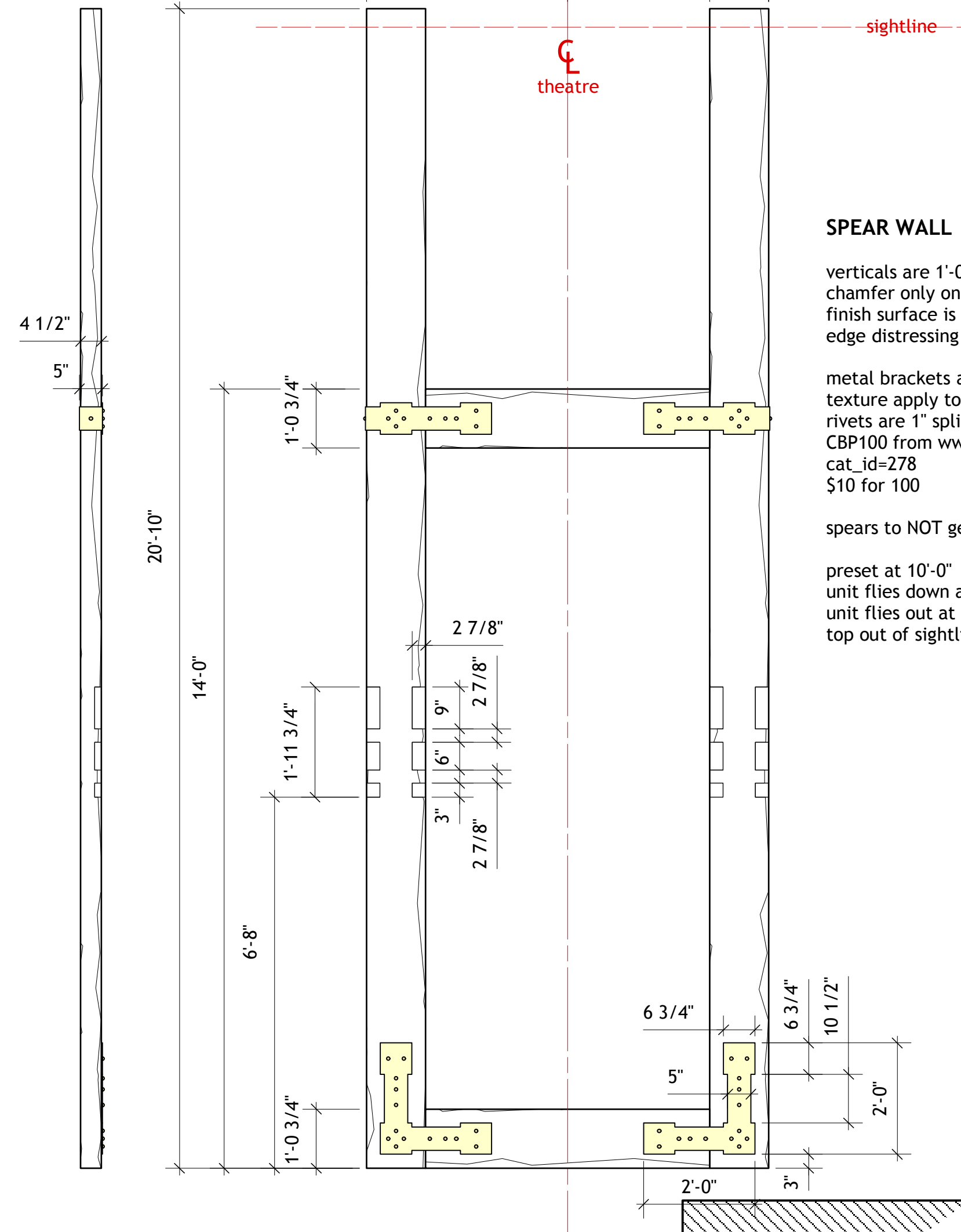

front view w/o spears



plan view w/o spears

SPEAR WALL

verticals are 1'-0 1/2" x 4 1/2"
 chamfer only on DS corners
 finish surface is rough/worn wood
 edge distressing on DS & US edges
 metal brackets are 1/4" thick w/ hemi-sphere 'rivets'
 texture apply to replicate hammered metal look
 rivets are 1" split balls
 CBP100 from www.craftparts.com
 cat_id=278
 \$10 for 100
 spears to NOT get removed from wall
 preset at 10'-0"
 unit flies down after Lear's entrance
 unit flies out at end of scene
 top out of sightlines/attache to lineset #8

strap at 14'-0"
 wraps around
 back of unit

onstage view

downstage left view

upstage left view

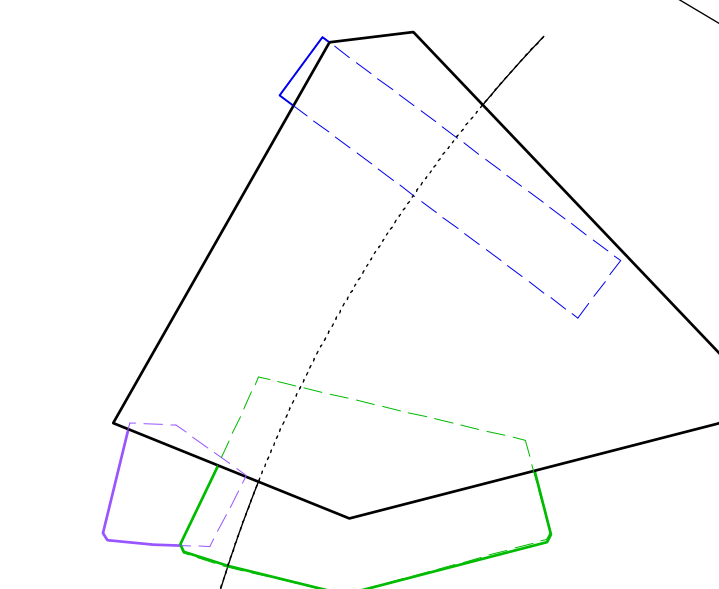
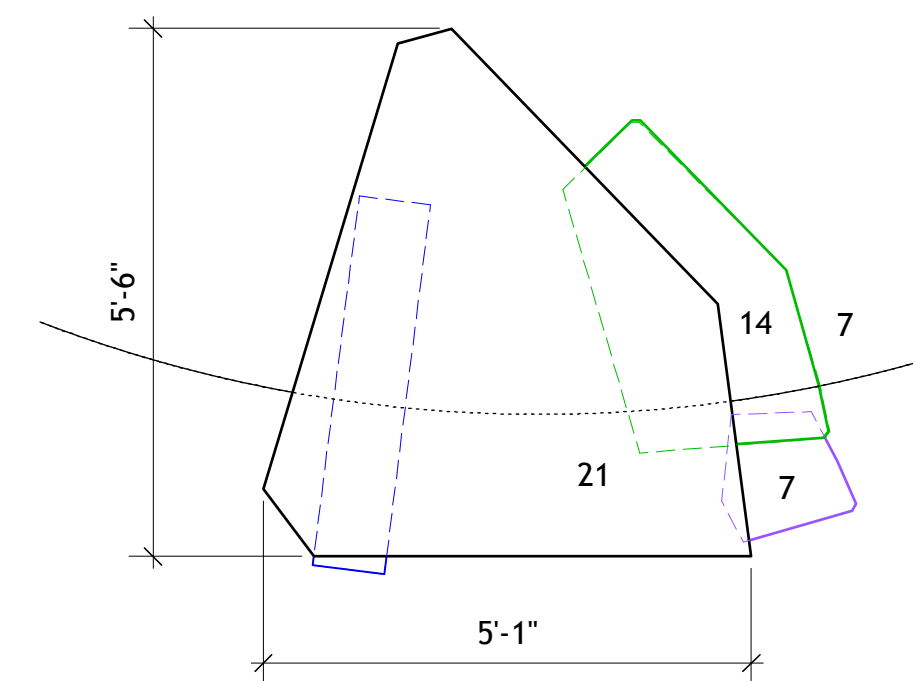
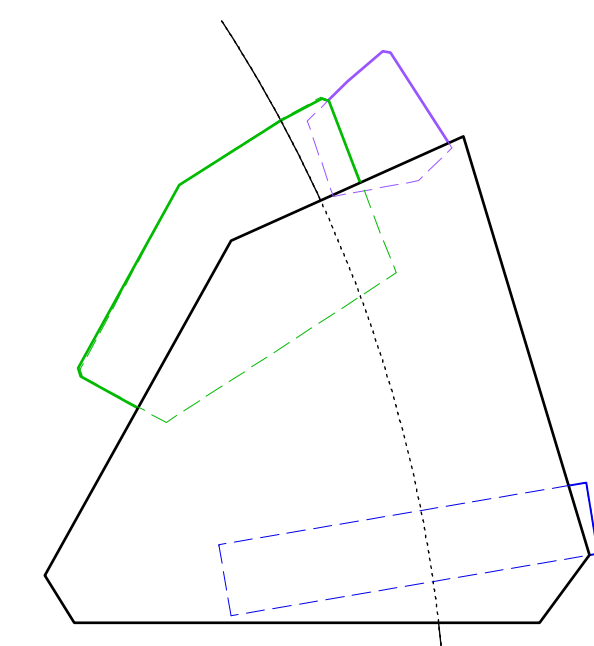

side view

front view

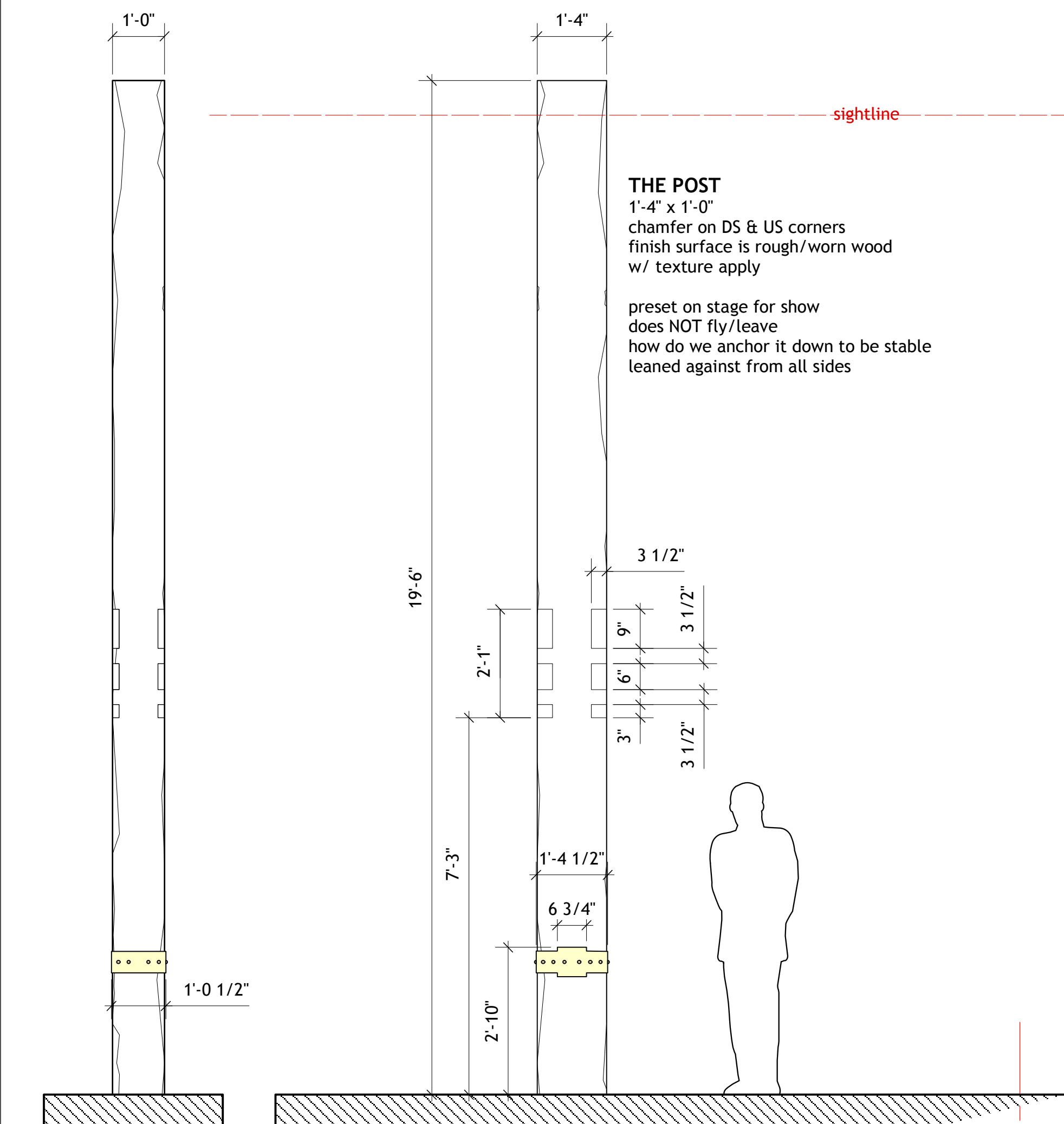

THE POST
 1'-4" x 1'-0"
 chamfer on DS & US corners
 finish surface is rough/worn wood
 w/ texture apply

preset on stage for show
 does NOT fly/leave
 how do we anchor it down to be stable
 leaned against from all sides

strap
 wraps around
 back of unit

section through chamfer

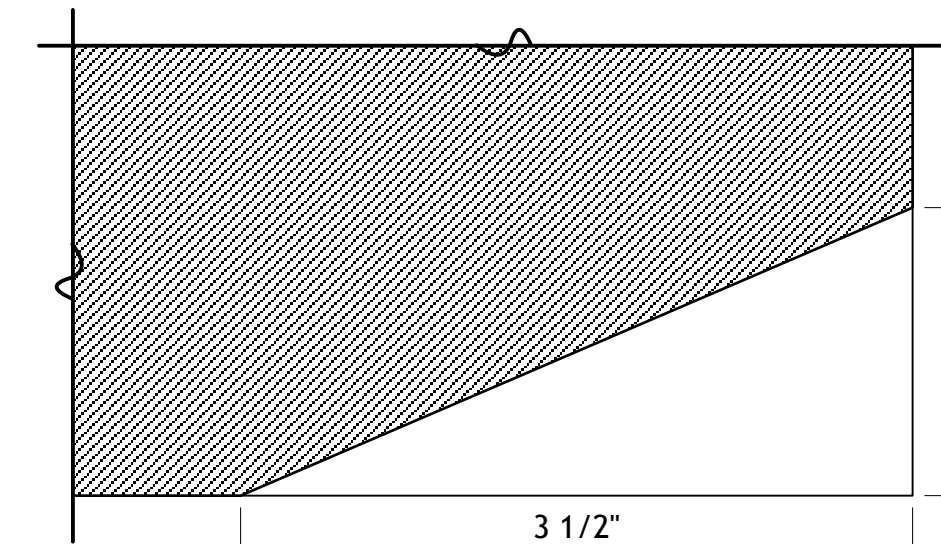

full scale section through chamfer

DL SITTABLE

rough stone finish
 cut/carve/grind all surfaces
 facings no clean 90 degree surfaces
 1/2" celotex or similar on skin for carving
 confirm height of season platform
 since this hangs off edge of it
 unit is stood/sat on by multiple actors

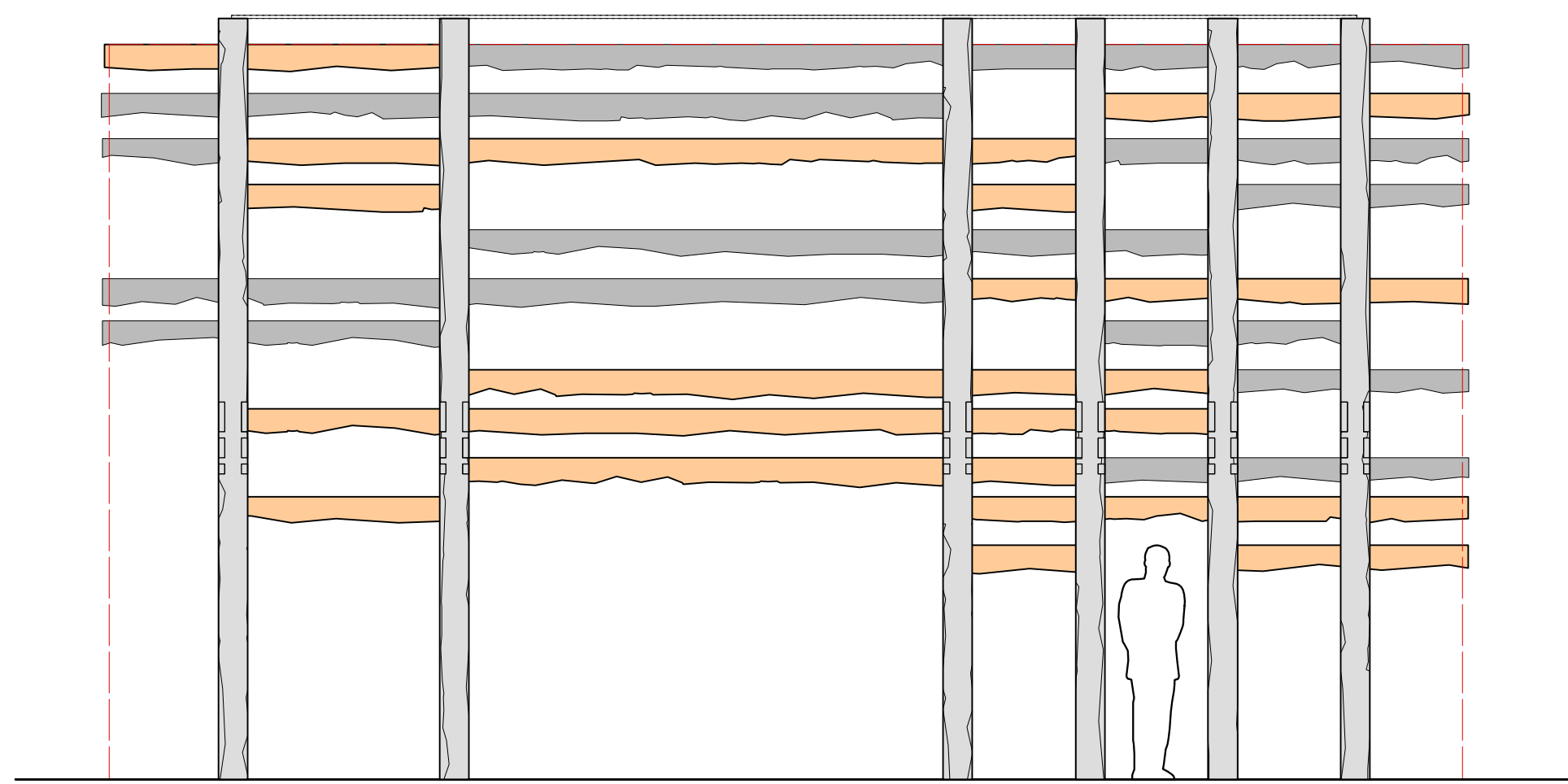

top of show | slats in | 1/4" = 1'-0"

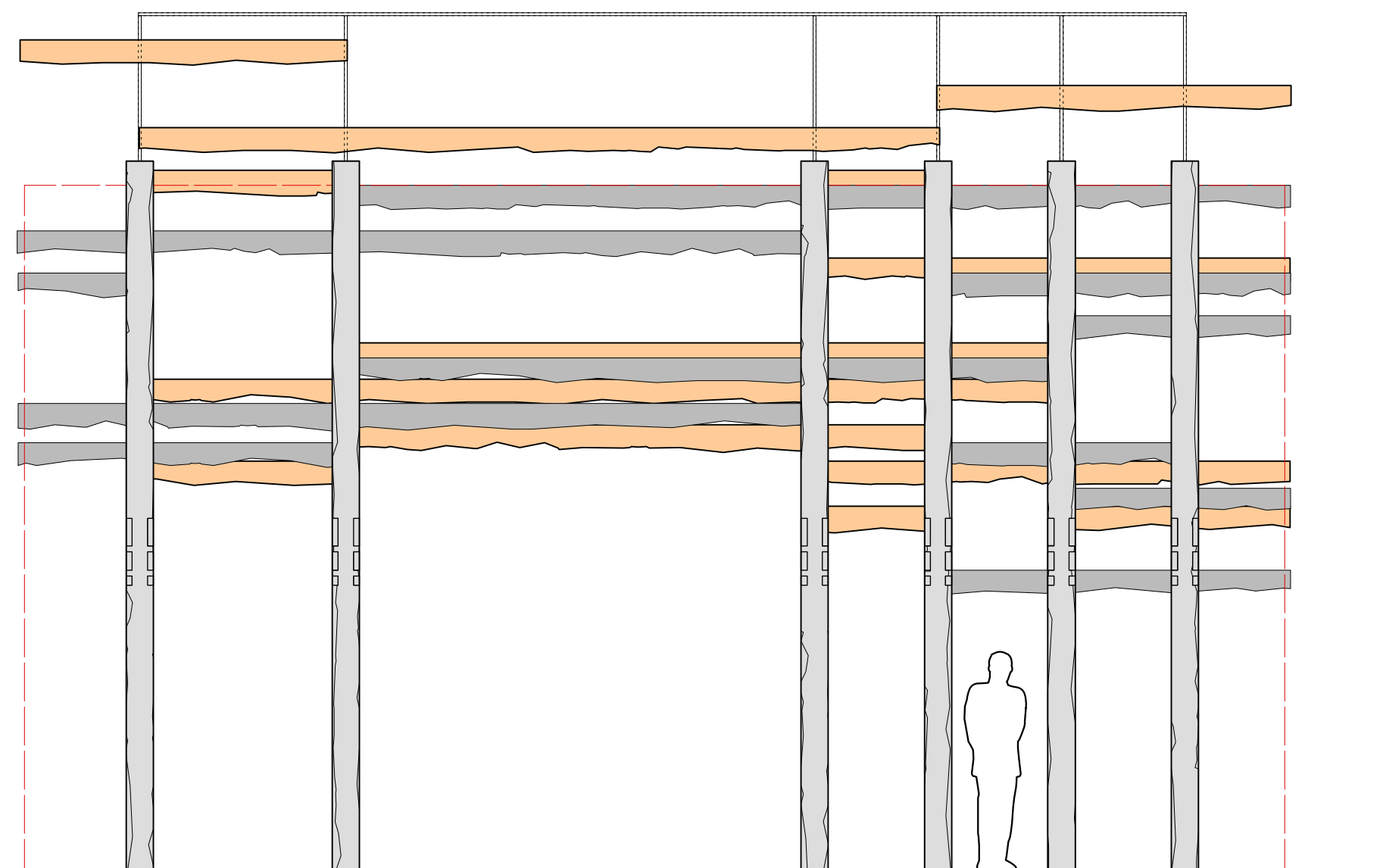

slats out 4'-0" | 1/4" = 1'-0"

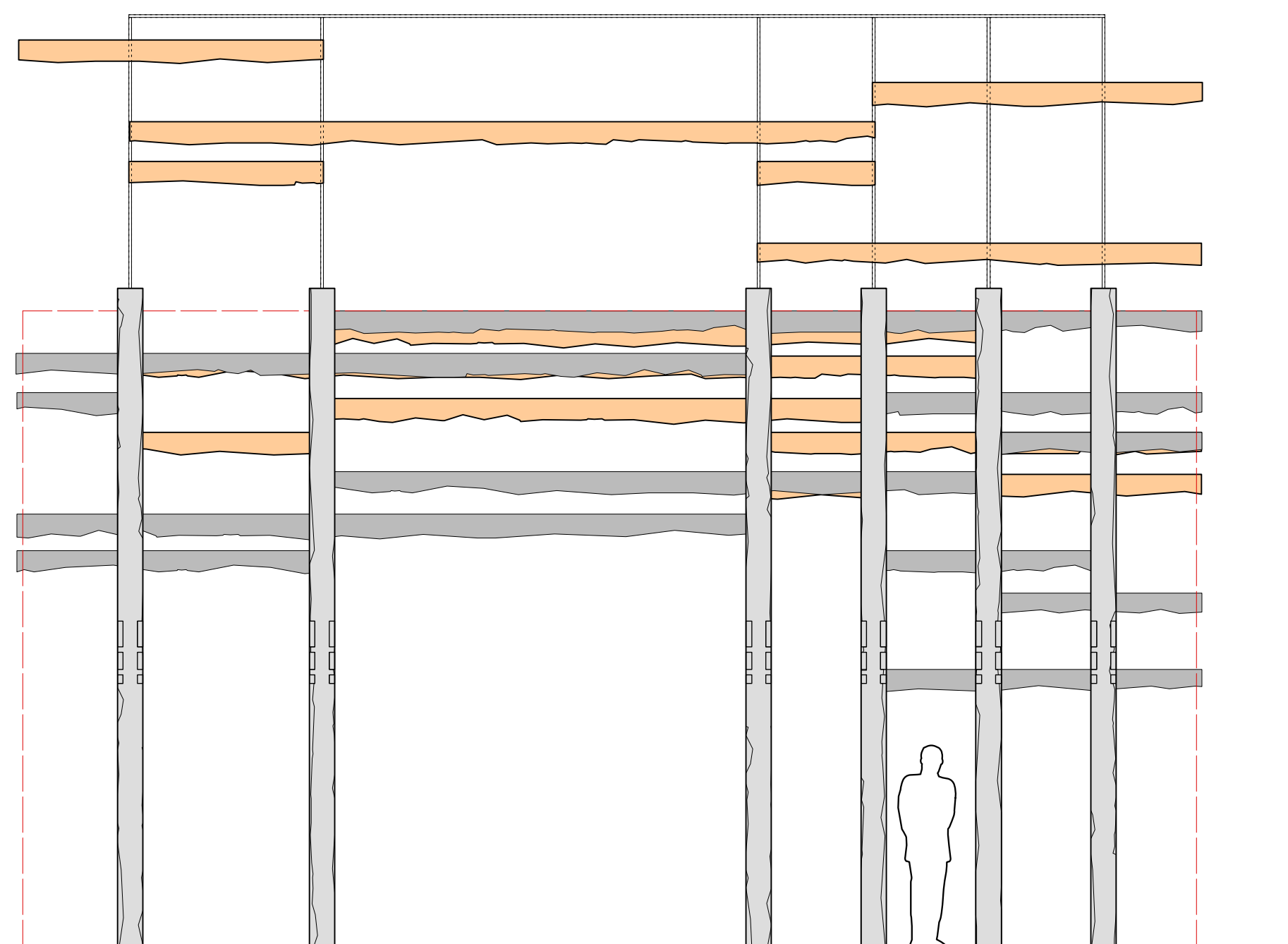

slats out 8'-0" | 1/4" = 1'-0"

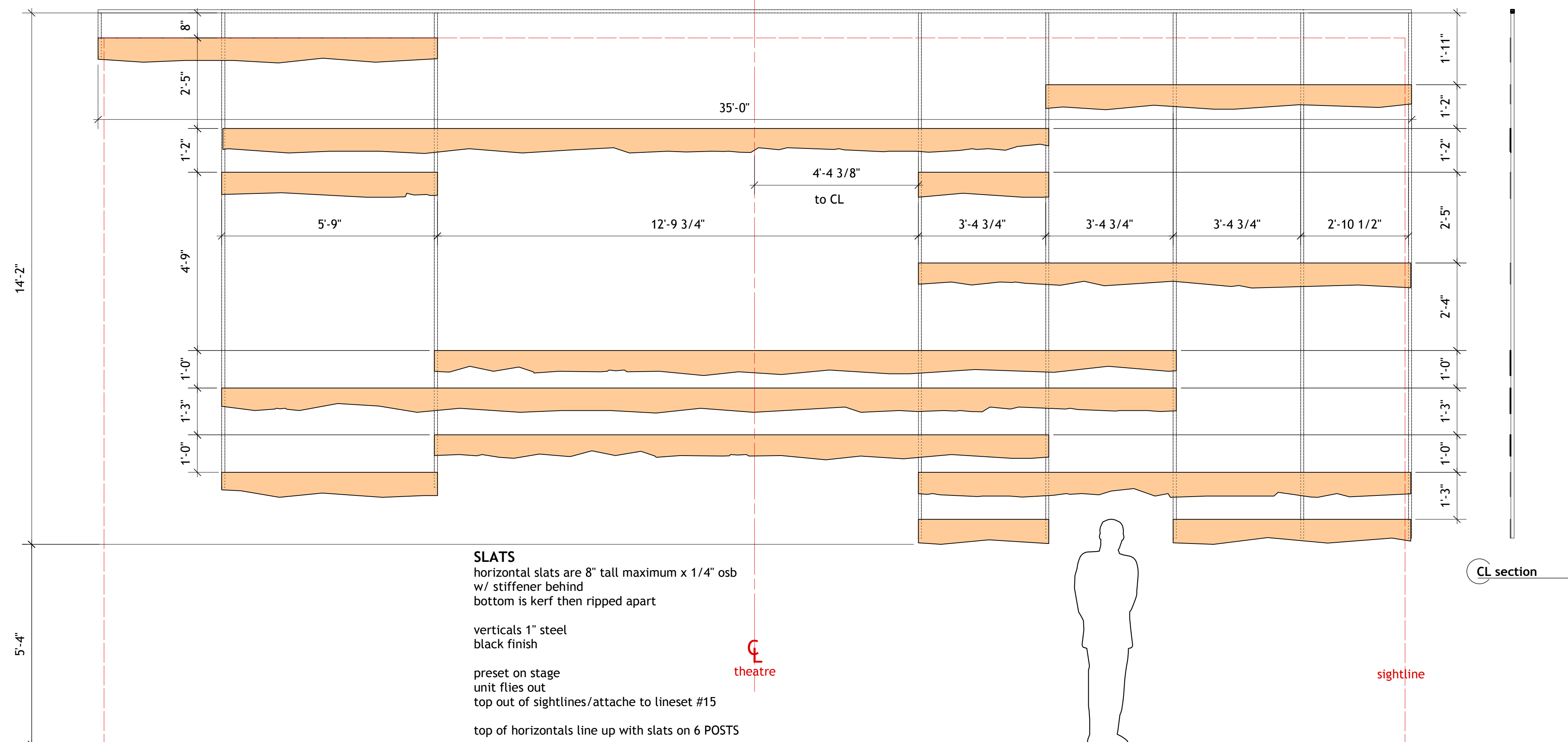

SLATS
horizontal slats are 8" tall maximum x 1/4" osb w/ stiffener behind
bottom is kerf then ripped apart

verticals 1" steel
black finish

preset on stage
unit flies out
top out of sightlines/attache to lineset #15

top of horizontals line up with slats on 6 POSTS

front view of SLATS

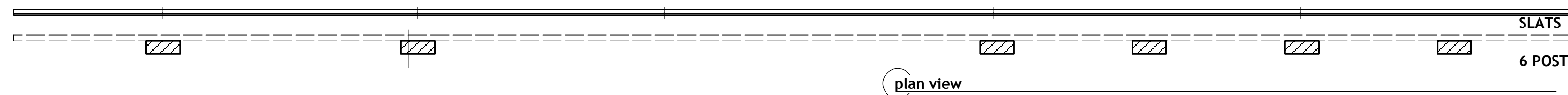

plan view

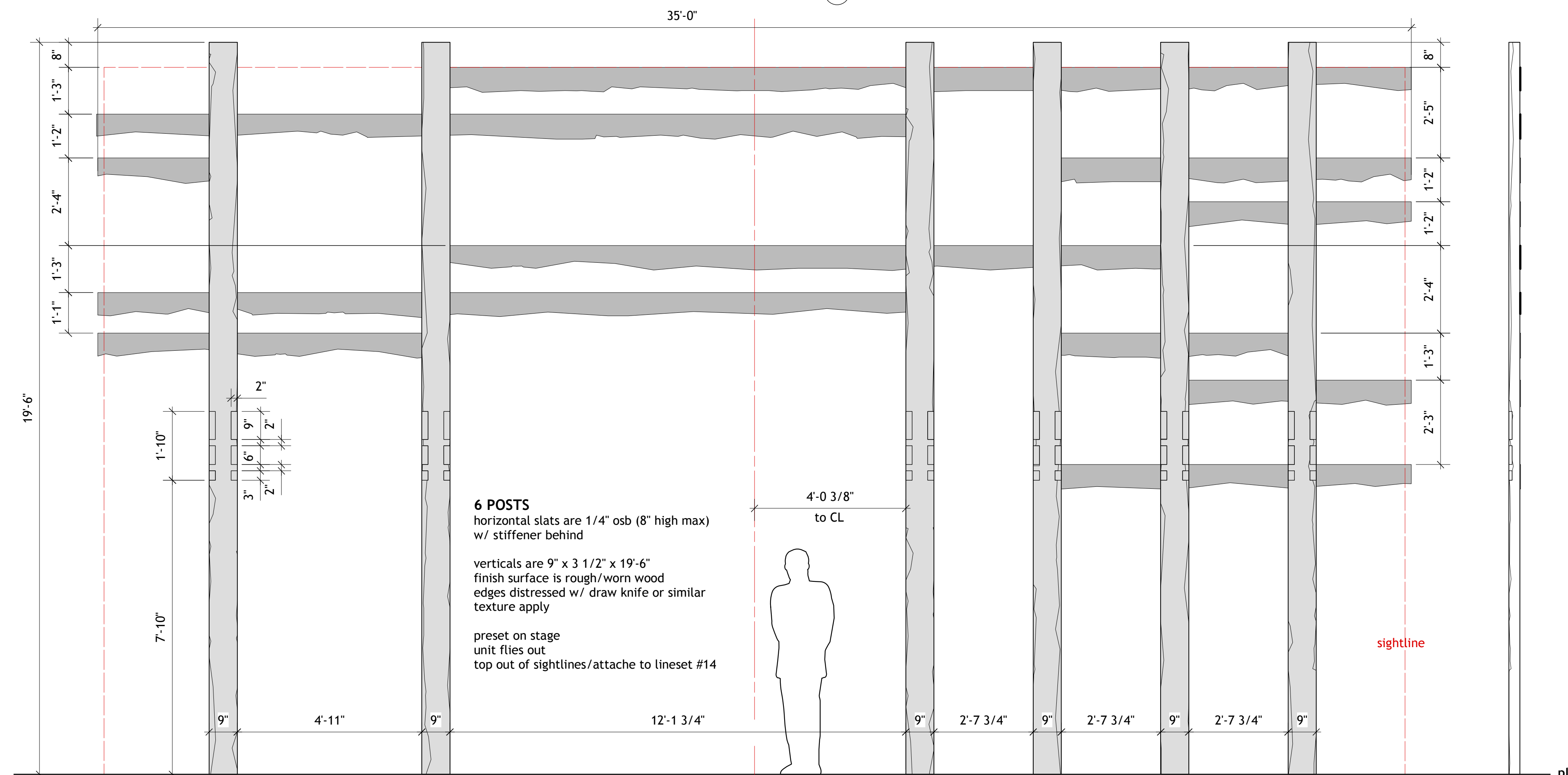

6 POSTS
horizontal slats are 1/4" osb (8" high max)
w/ stiffener behind

verticals are 9" x 3 1/2" x 19'-6"
finish surface is rough/worn wood
edges distressed w/ draw knife or similar
texture apply

preset on stage
unit flies out
top out of sightlines/attache to lineset #14

front view of 6 POSTS

CL section

CL section

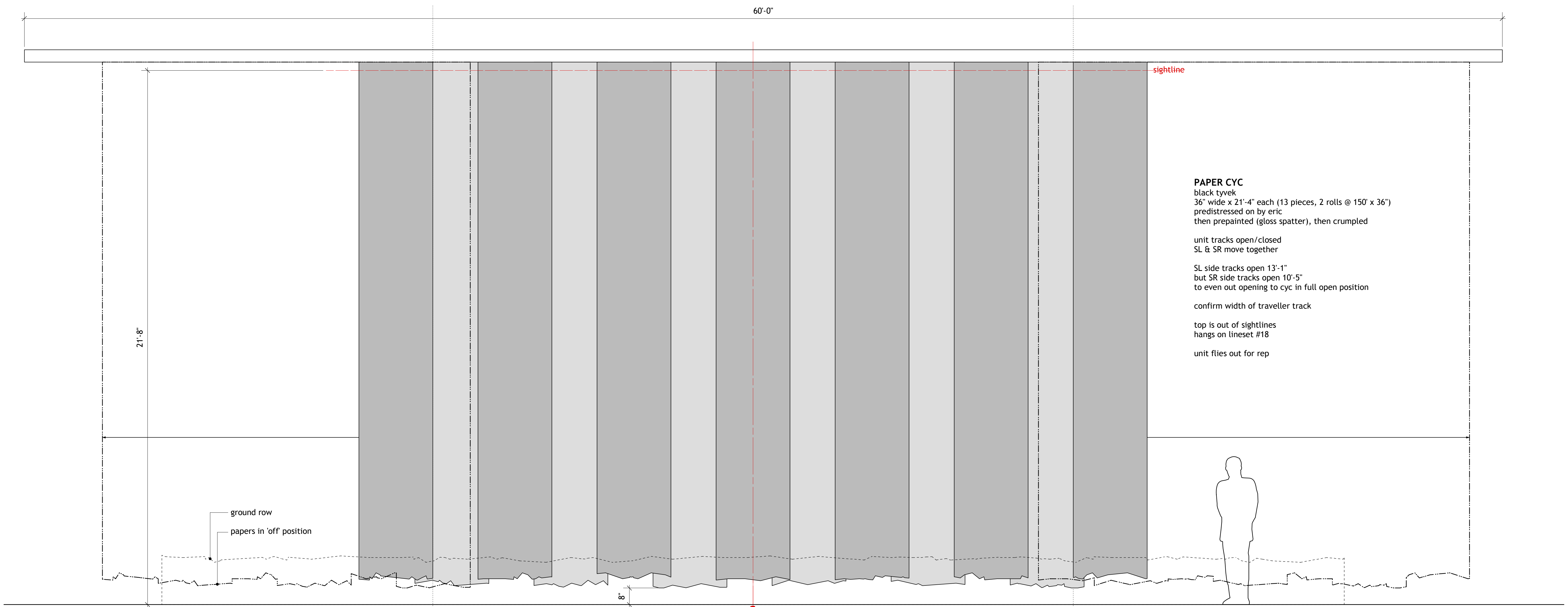

PAPER CYC
 black tyvek
 36" wide x 21'-4" each (13 pieces, 2 rolls @ 150' x 36")
 prestressed on by eric
 then preprinted (gloss spatter), then crumpled

unit tracks open/closed
 SL & SR move together

SL side tracks open 13'-1"
 but SR side tracks open 10'-5"
 to even out opening to cyc in full open position

confirm width of traveller track

top is out of sightlines
 hangs on lineset #18

unit flies out for rep

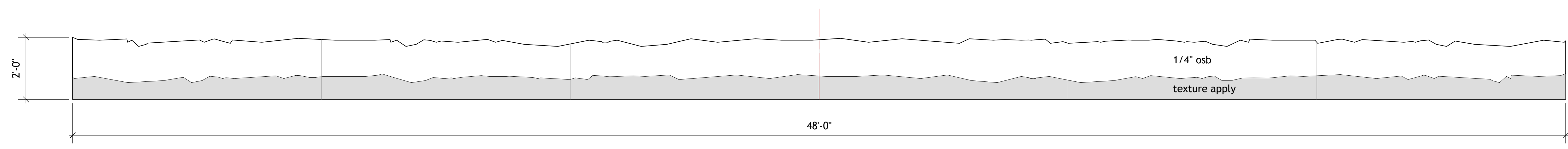
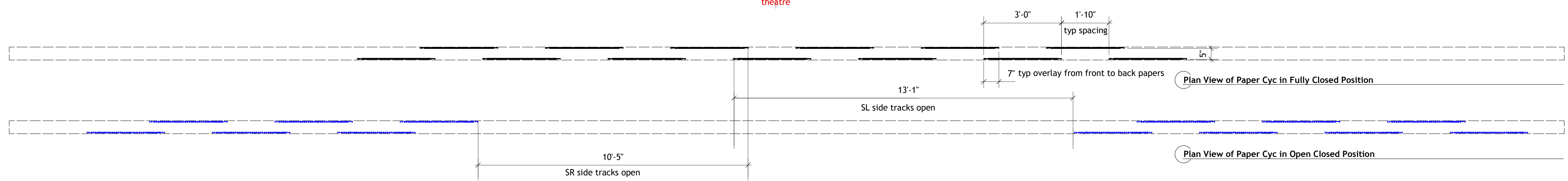

GROUND ROW
 1/4" osb front
 gloss black
 texture apply + smooth out bottom -8"
 unit does not need to move for season
 anchor down/brace US

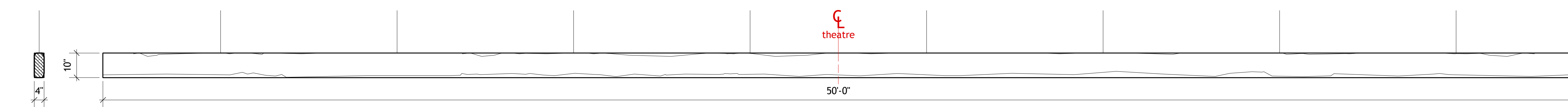

BEAM #1
 50'-0" x 10" x 4"
 finish is aged/rough wood
 edges notched down as if w/ draw knife
 confirm spacing on existing battens,
 can we replicate that spacing for beam #1?
 1/8" aircraft cable (20' to batten)
 unit flies up/down (18' throw)
 top & bottom seen

BEAM #2 & 3
 existing lineset
 faux aged/black/rusty any 'modern' marks
 unit flies up/down throughout show

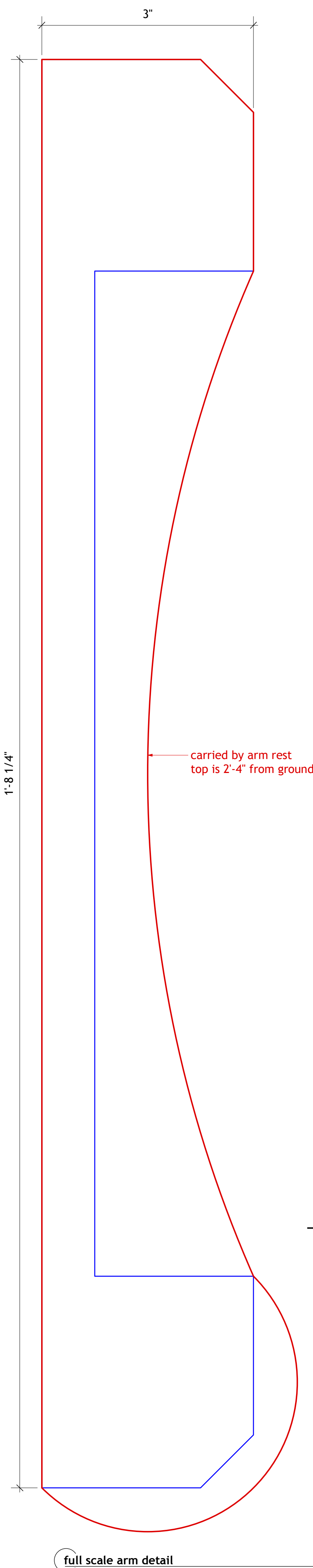

full scale arm detail

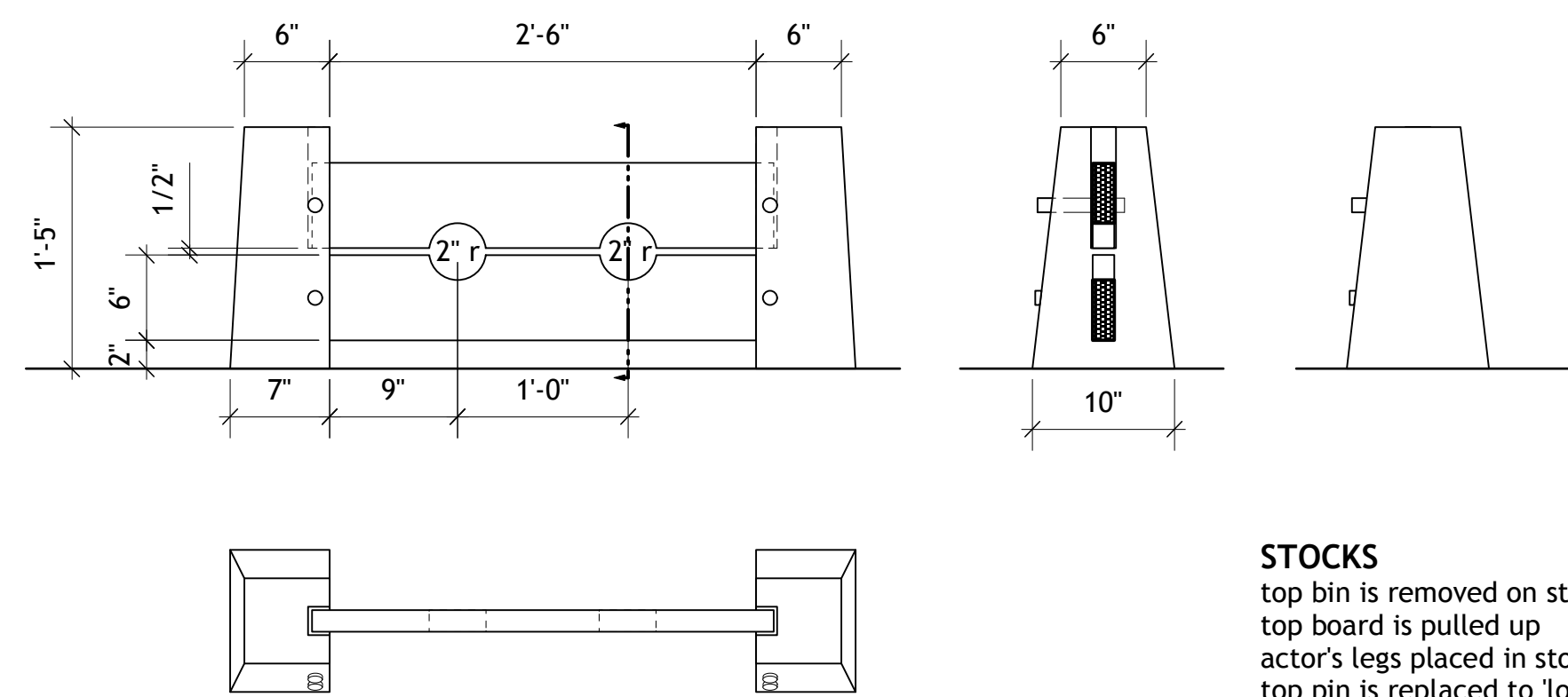

STOCKS
 top bin is removed on stage
 top board is pulled up
 actor's legs placed in stocks
 top pin is replaced to 'lock' stocks
 actor sits on low stump, against the post

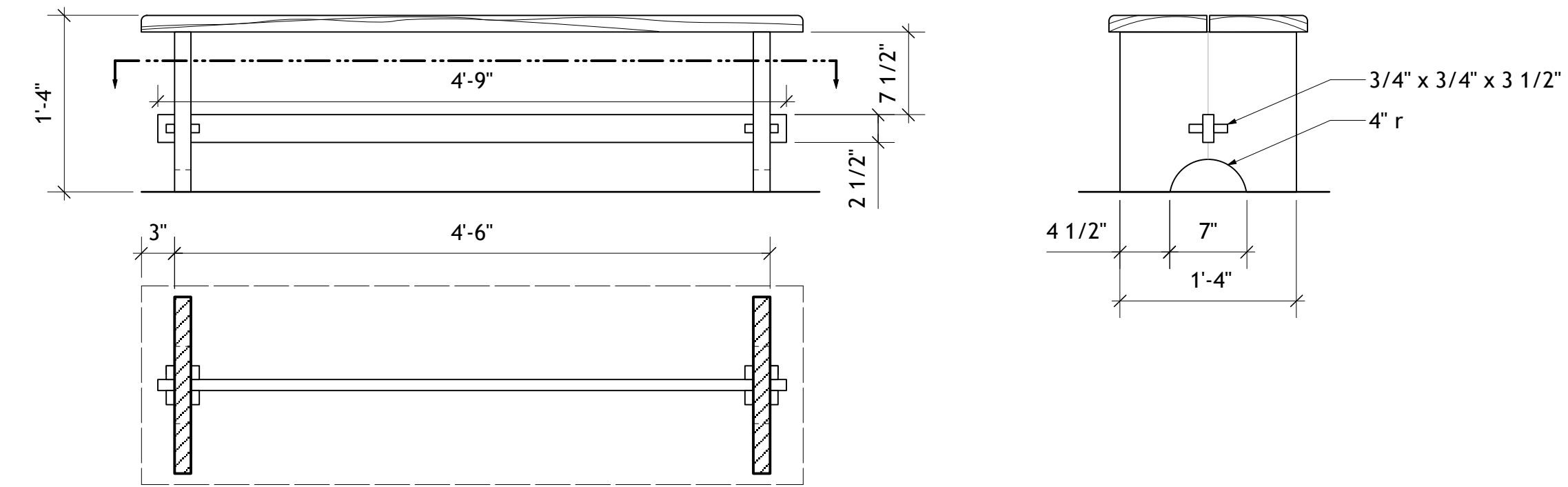

BENCHES
 build 2
 1 1/2" rough cut
 the top is 2 pieces of an exterior cut (rounded edges of the tree)
 aged/stained dark wood finish
 units live DSL and DSR, carried by 2 actors
 stood on

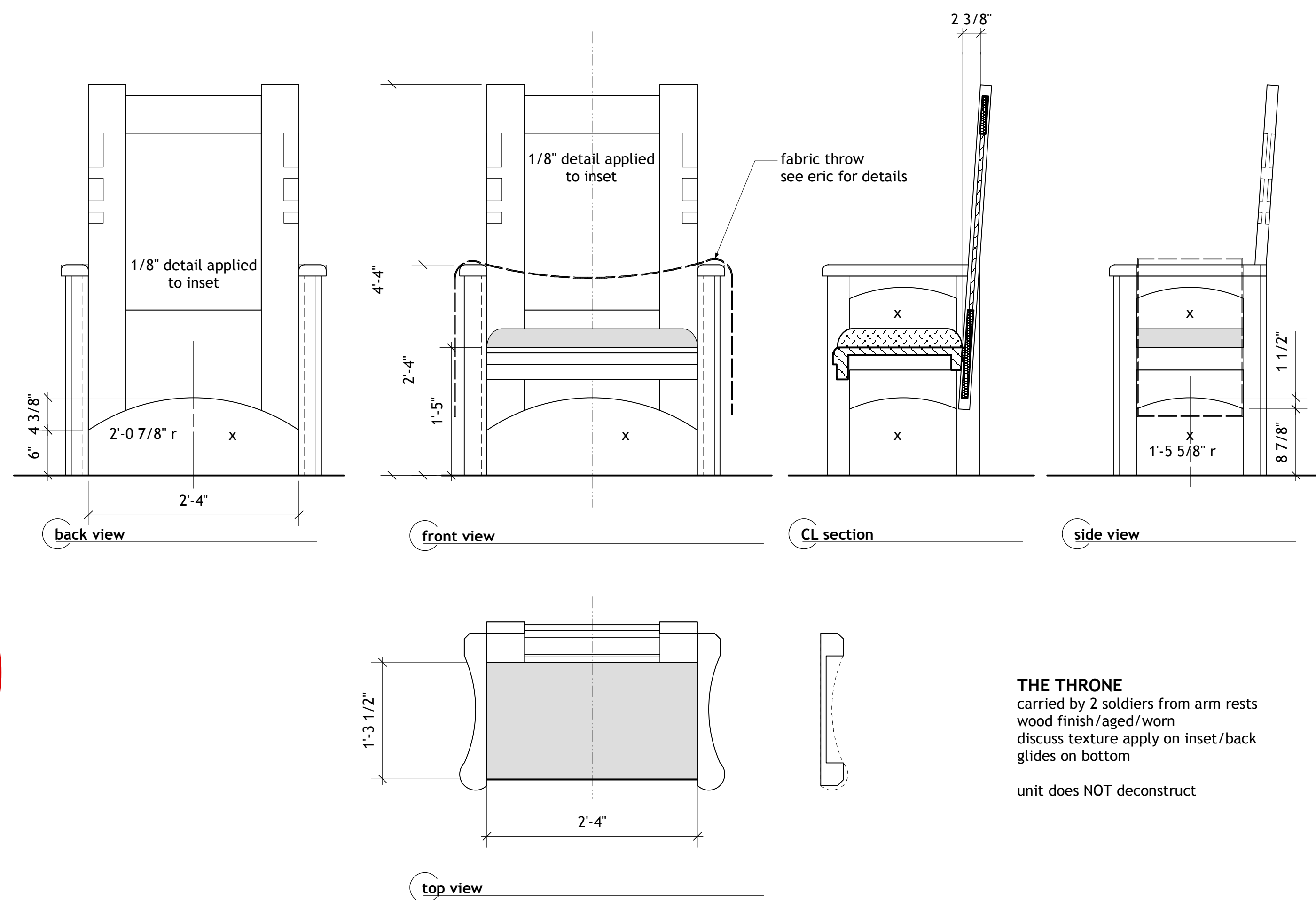

THE THRONE
 carried by 2 soldiers from arm rests
 wood finish/aged/worn
 discuss texture apply on inset/back
 glides on bottom
 unit does NOT deconstruct

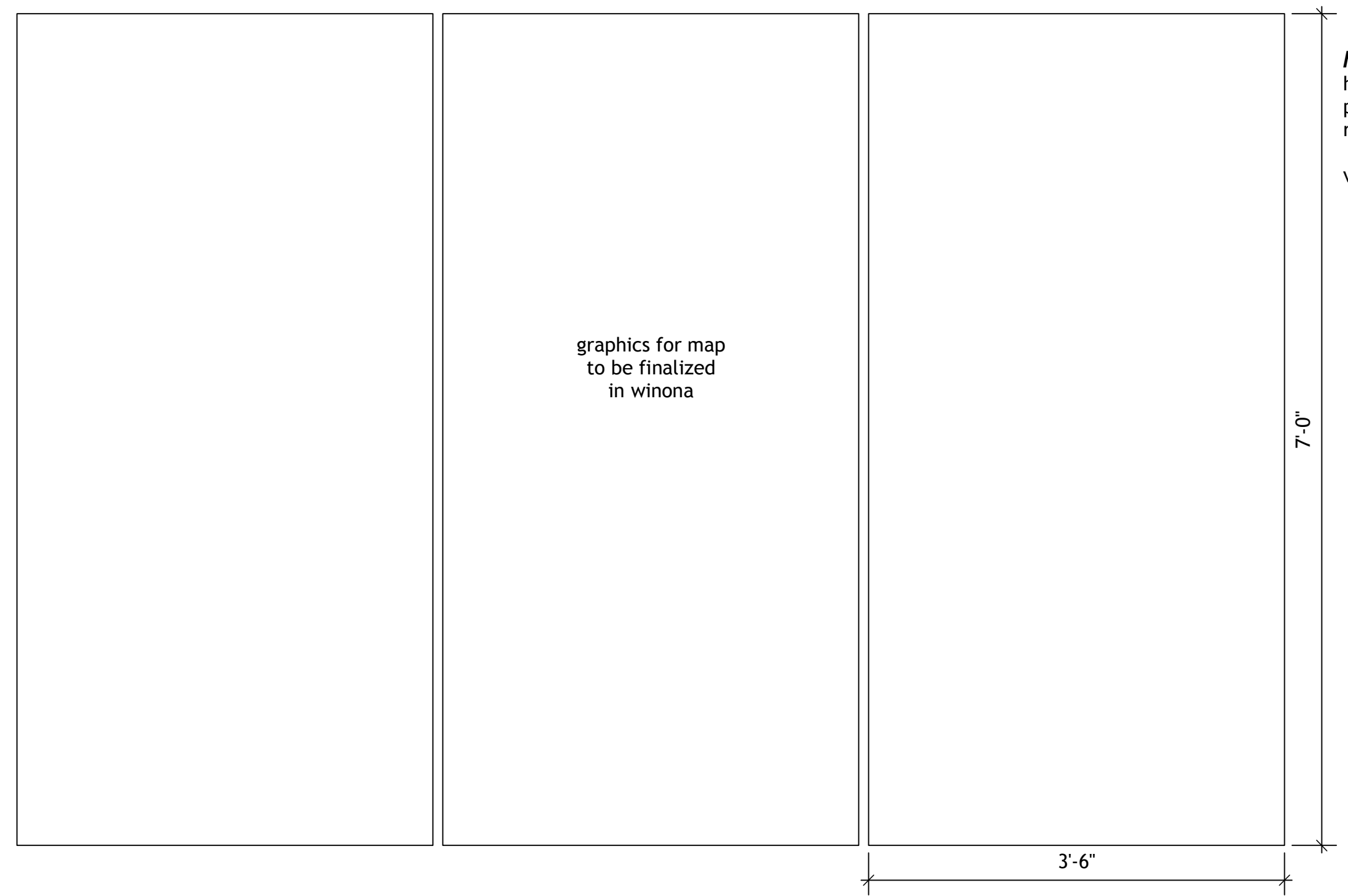

MAP PIECES
 heavy weight canvas
 painted/sepia tone detail
 rolled out onto deck by servants
 verify sizes prior to construction

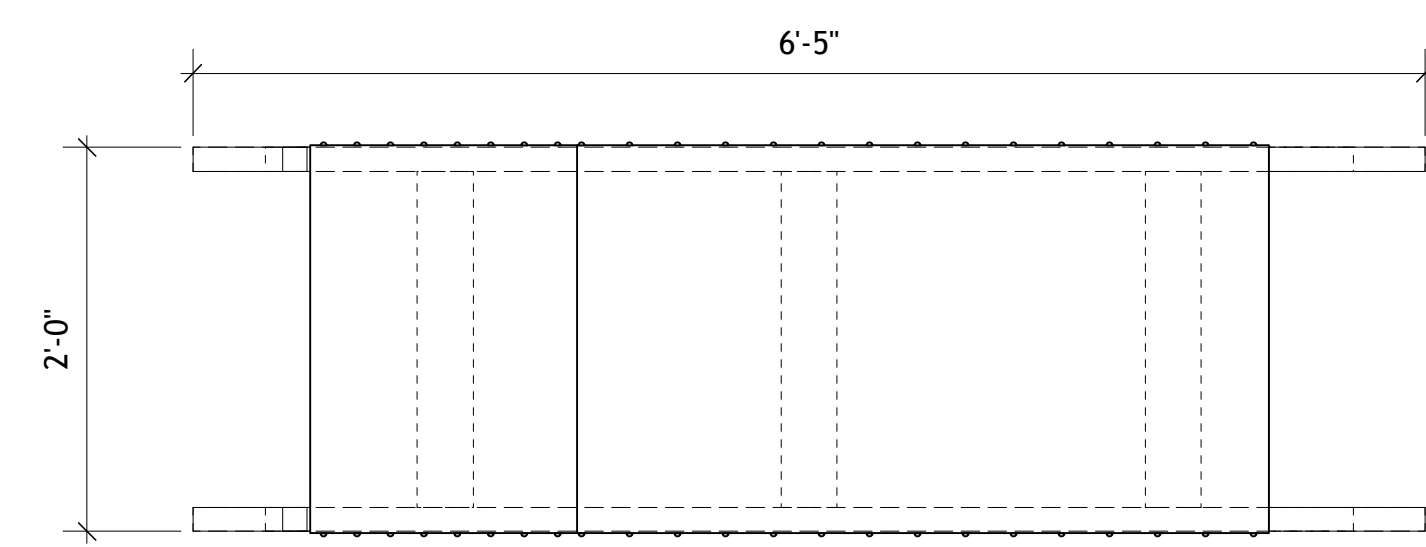
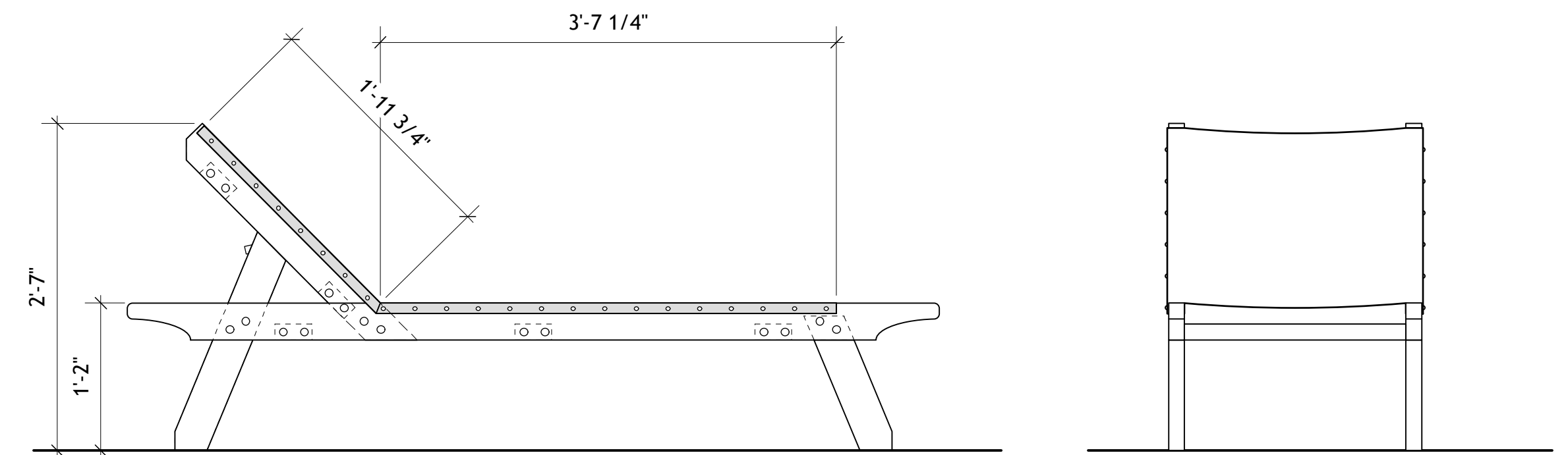

LITTER
 aged/stained dark wood finish
 Lear carried on by 4 actors
 2 x 4 construction
 discuss datto/lap joints
 metal fasteners w/ dowels?
 heavy weight canvas w/ -3/8" upholstery tacks
 also has loose cushion for back & blanket

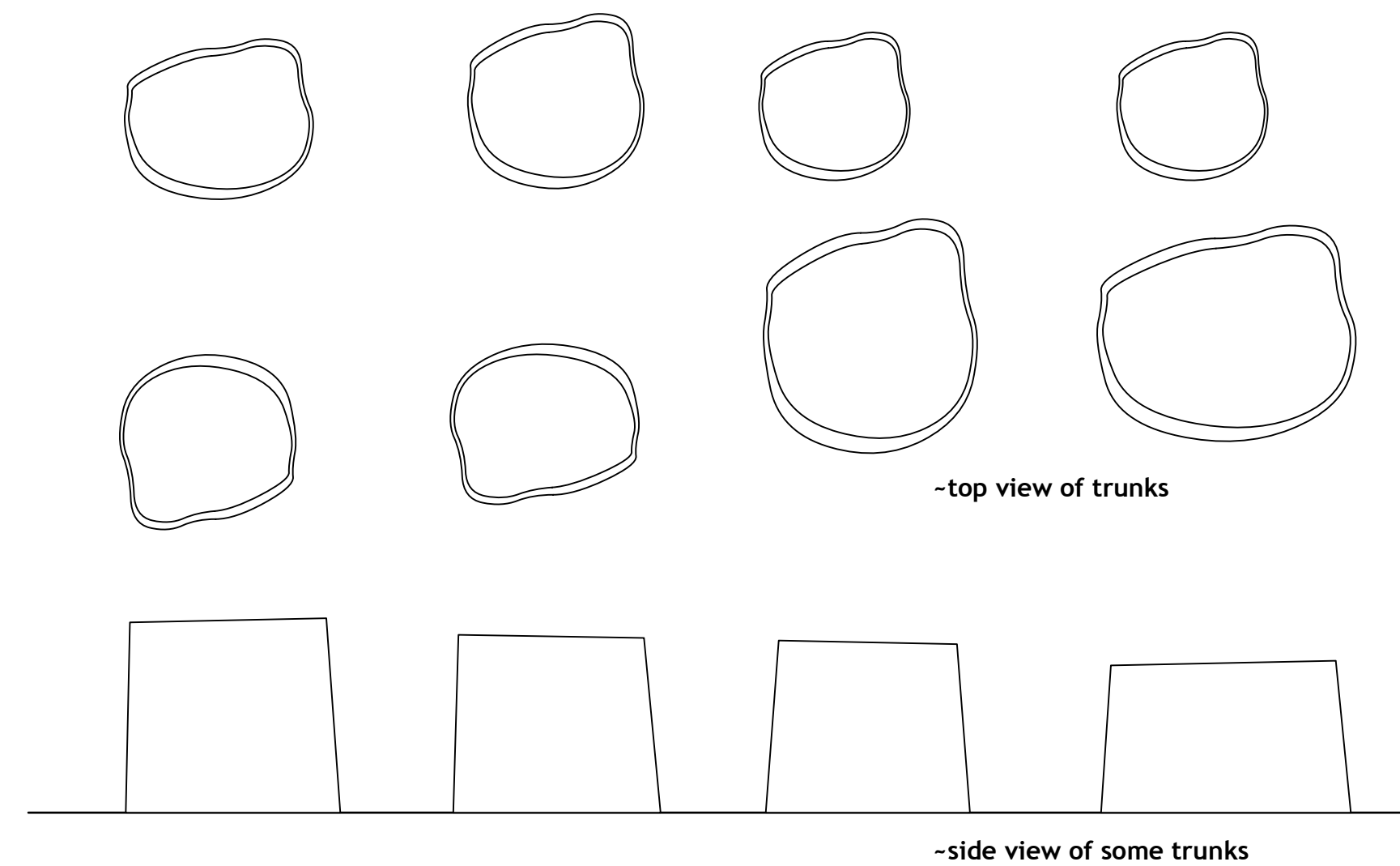

TRUNKS
 real 8 tree trunk slices
 from a local source
 sycamore, preferred
 8 units
 3 small
 3 medium
 2 large
 12" to 24" diameter
 12" to 18" tall

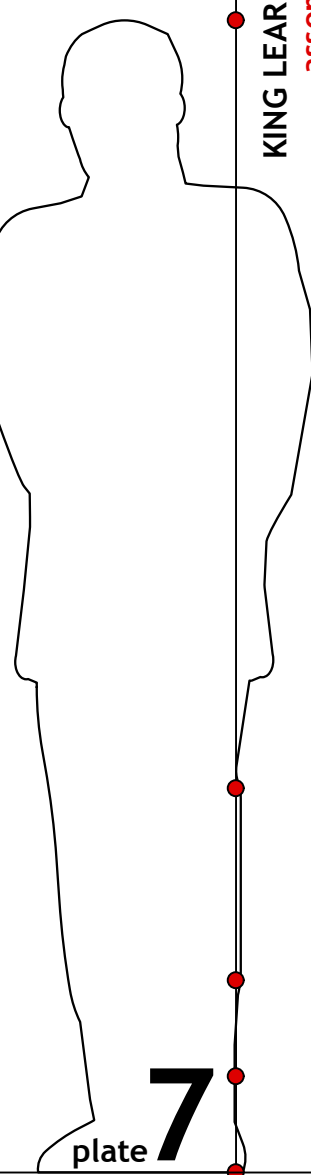

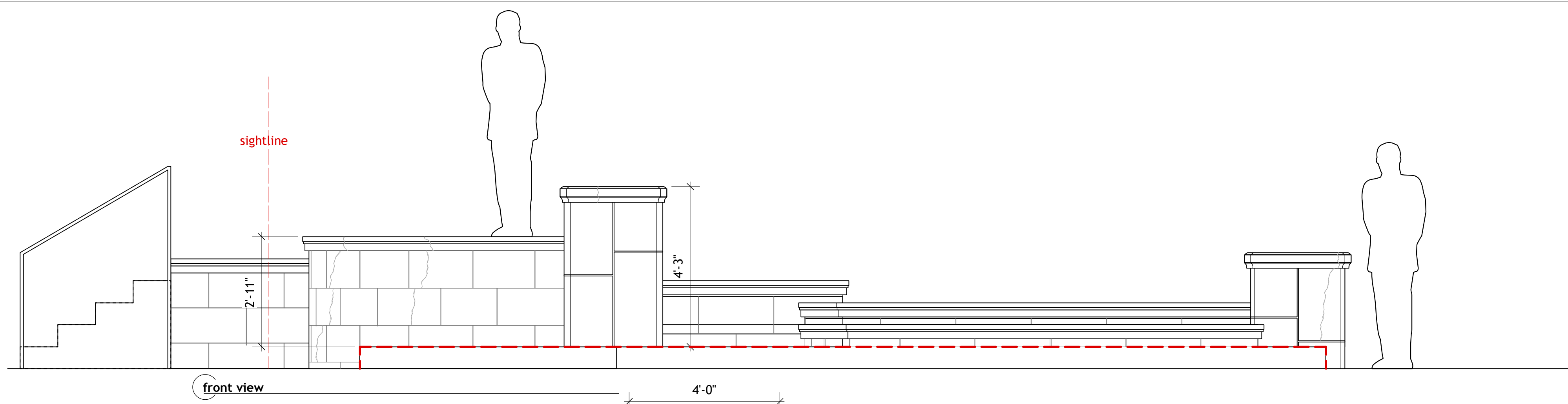

front view

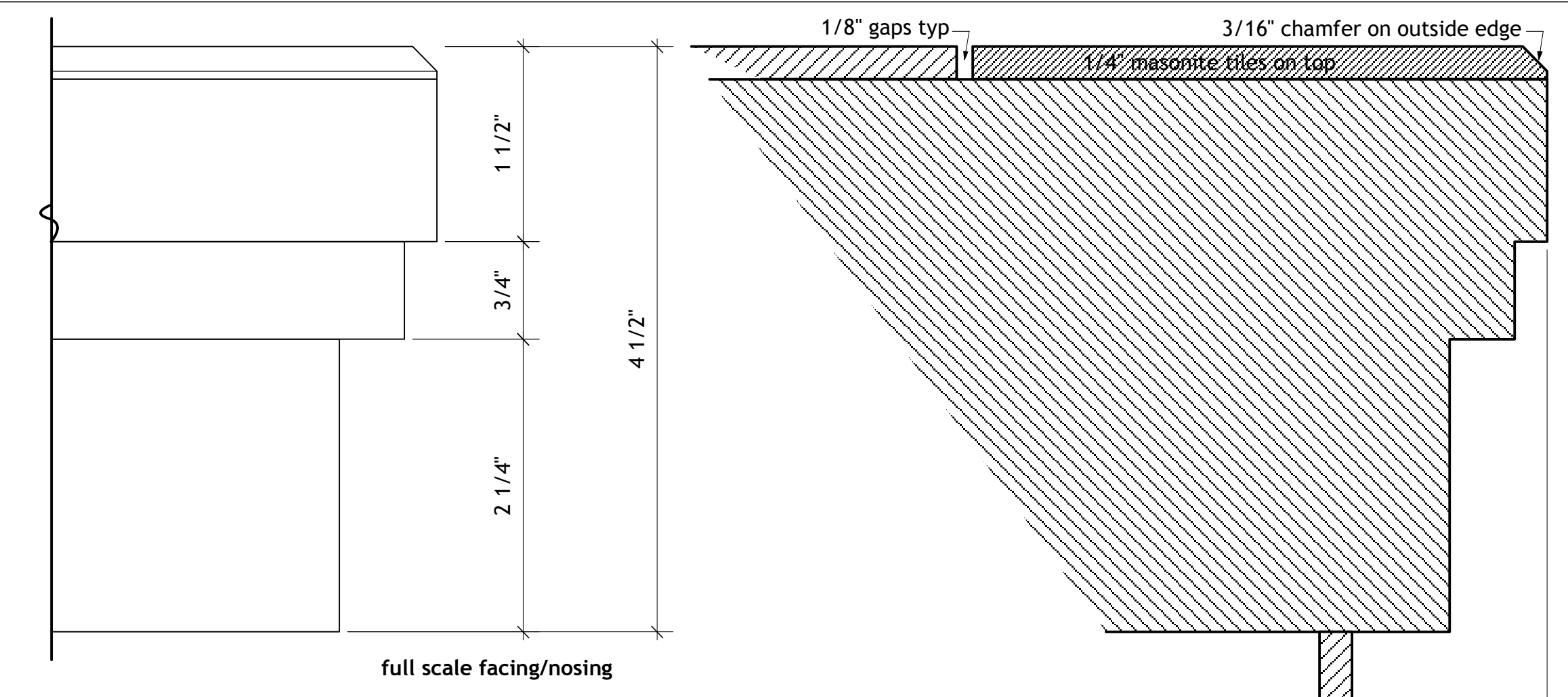

full scale facing/nosing

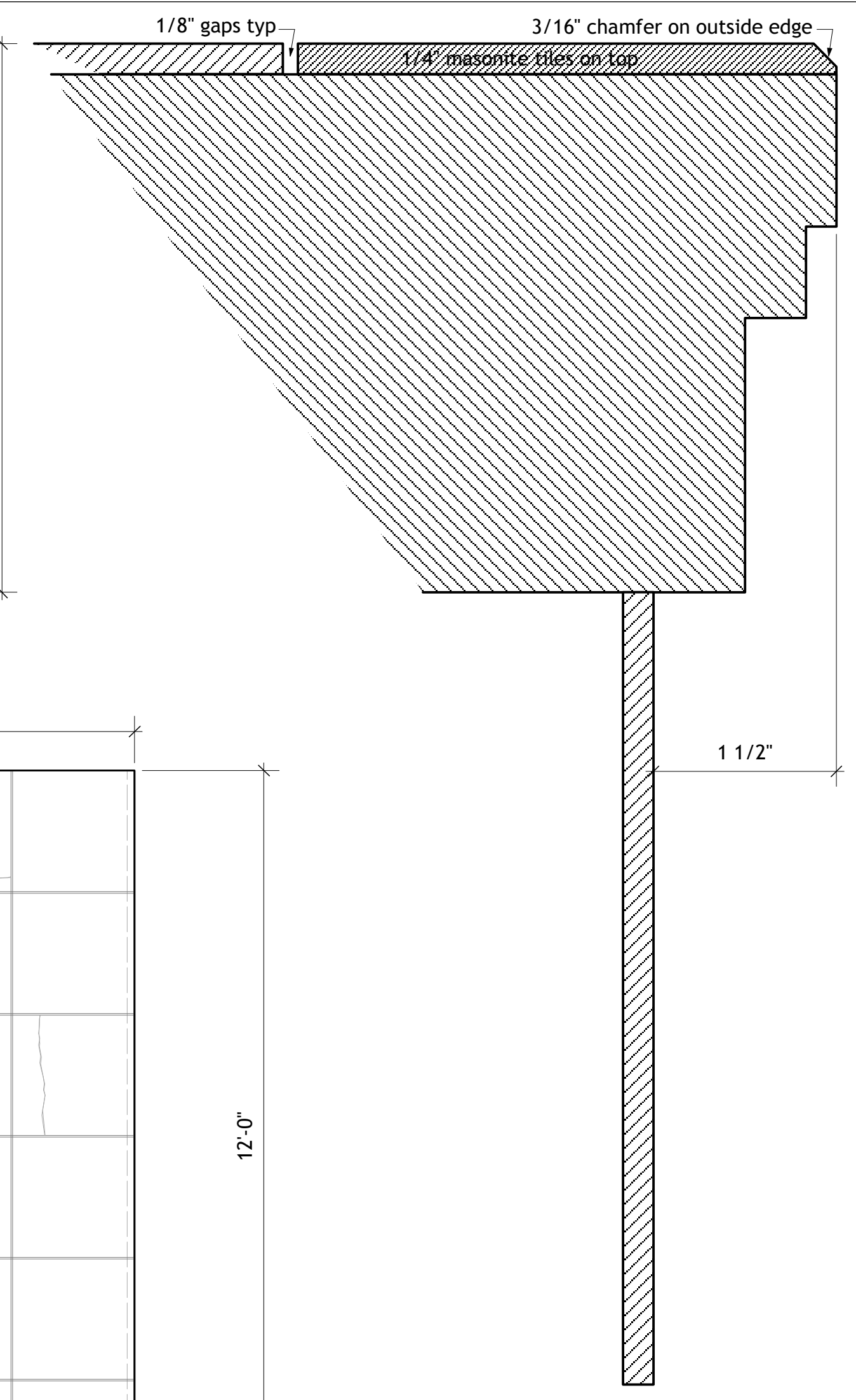

full scale facing/nosing

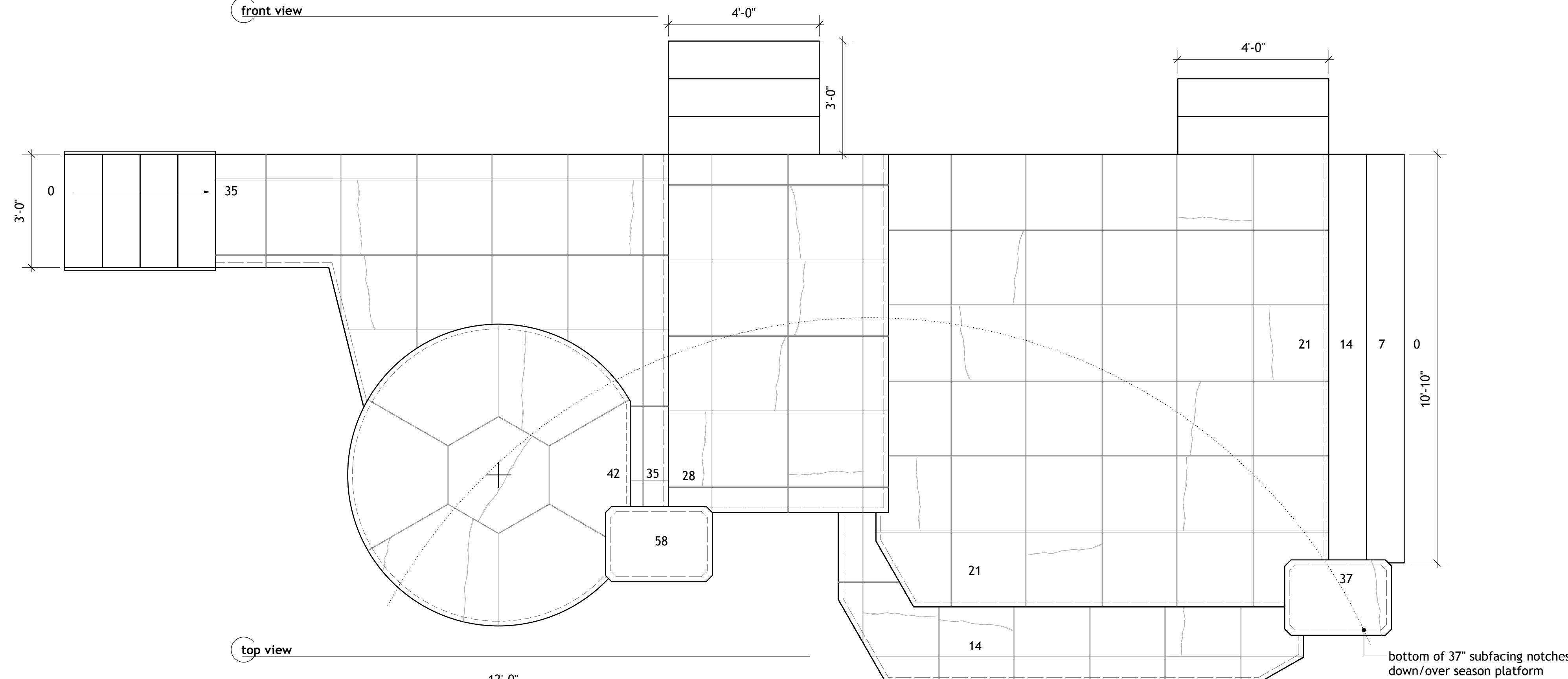

top view

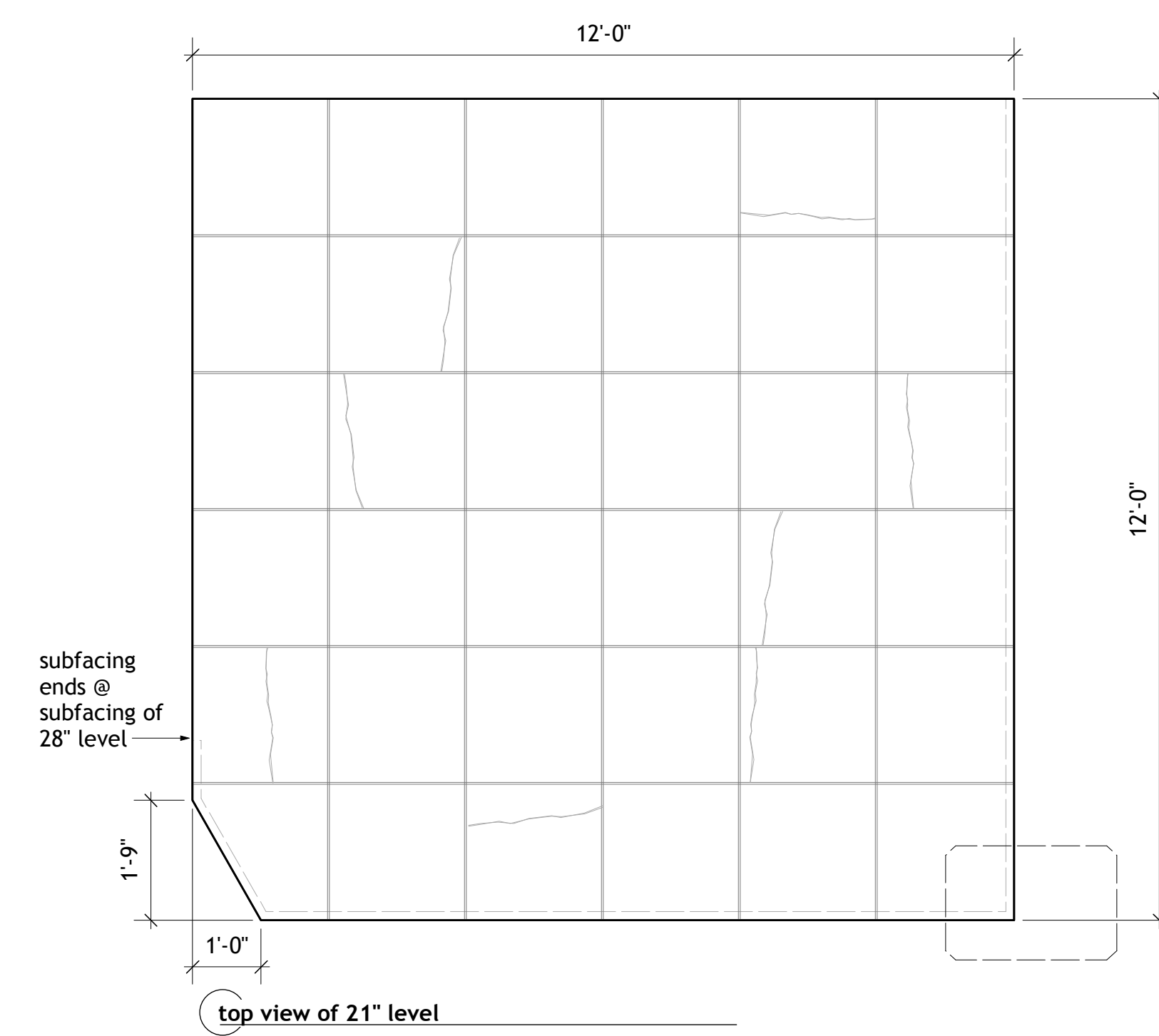

top view of 21" level

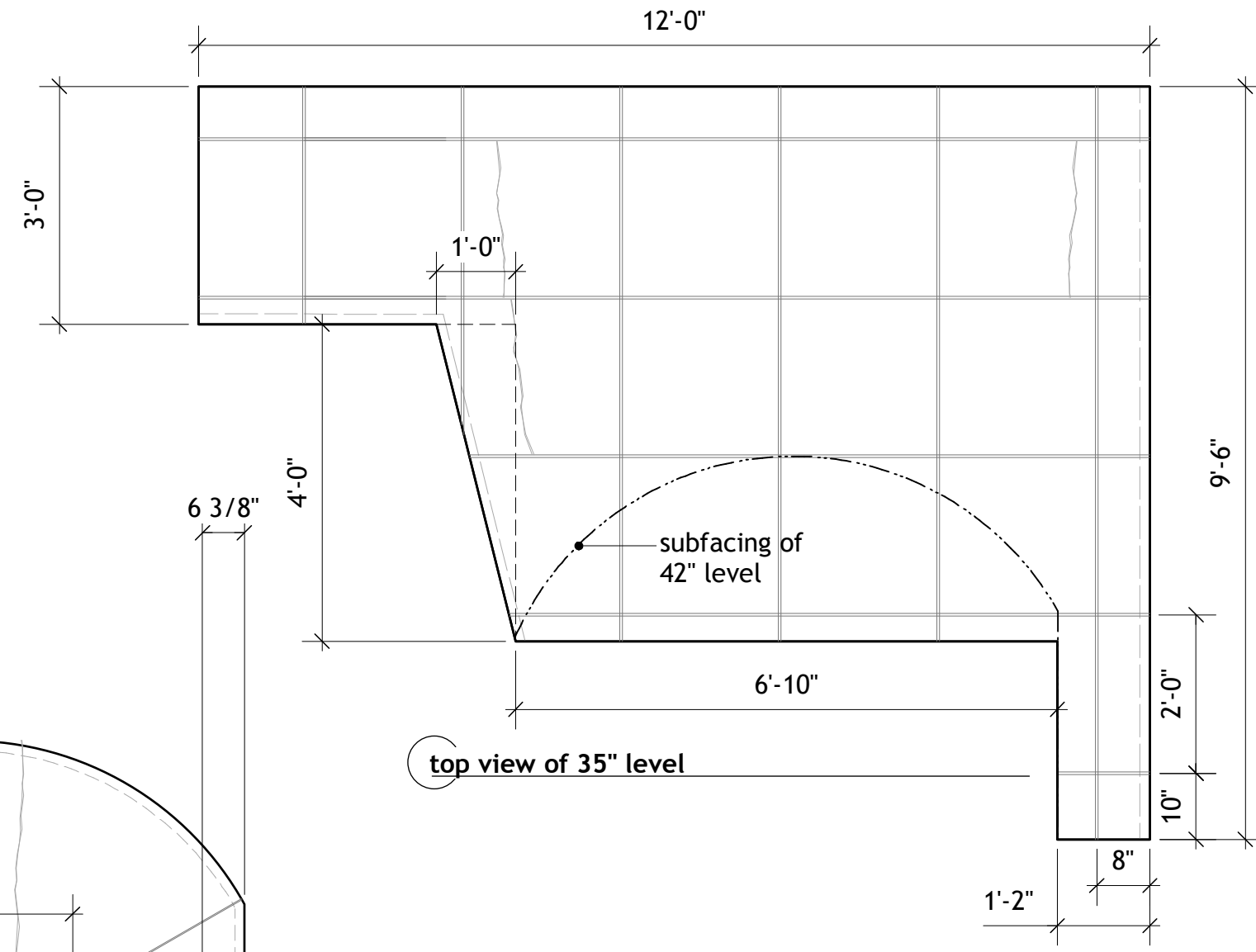

top view of 35" level

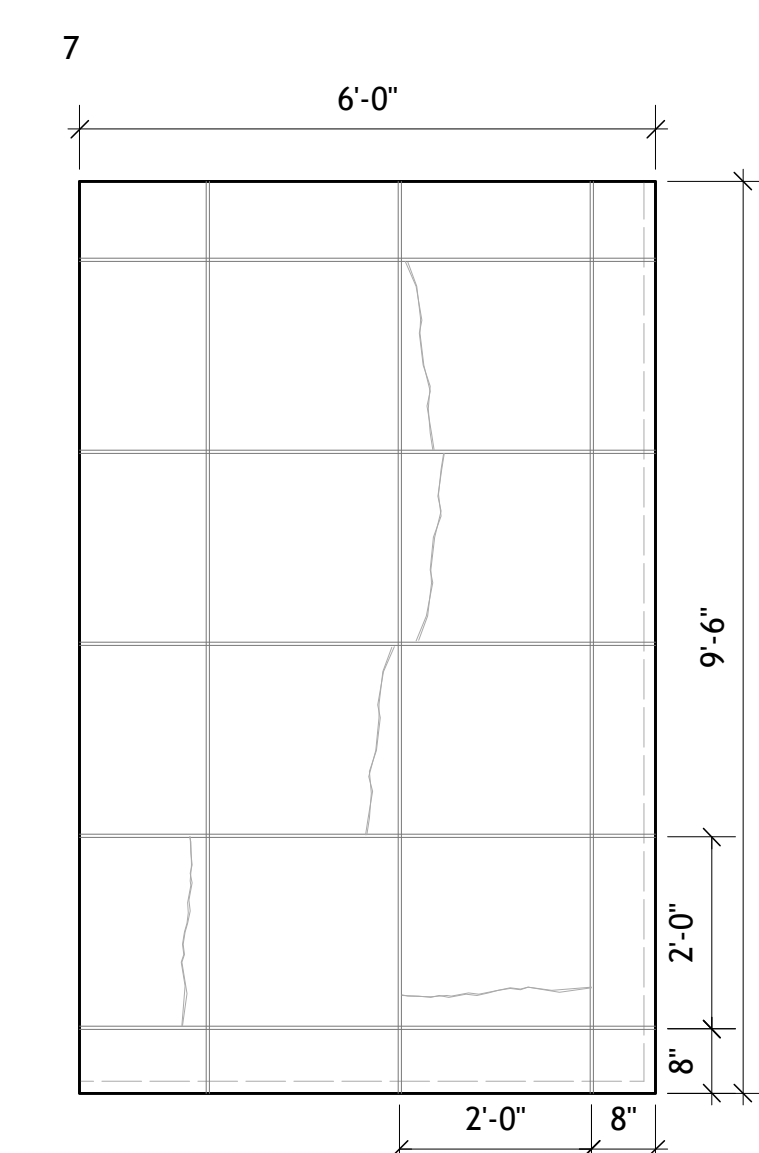

top view of 14" level

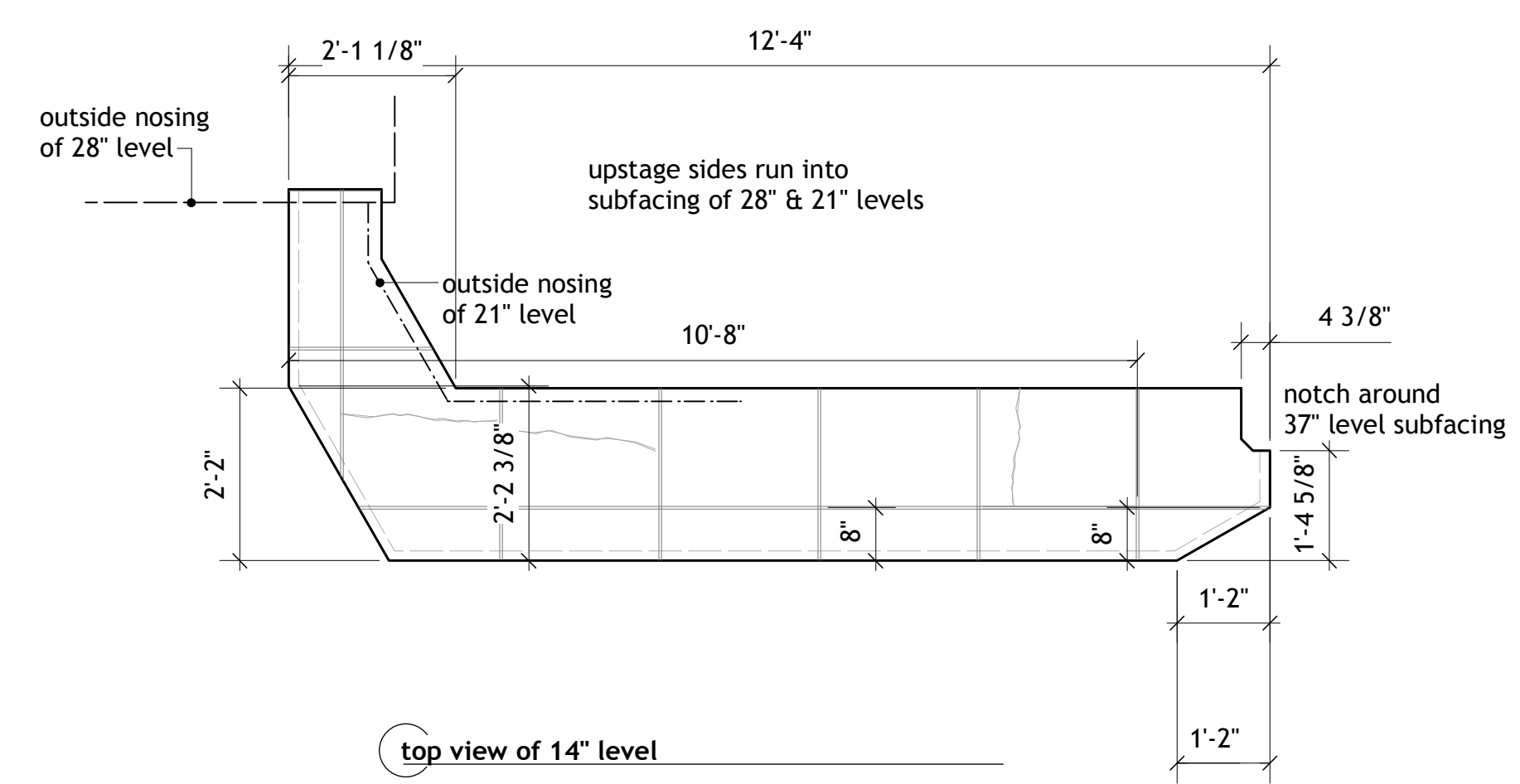

top view of 14" level

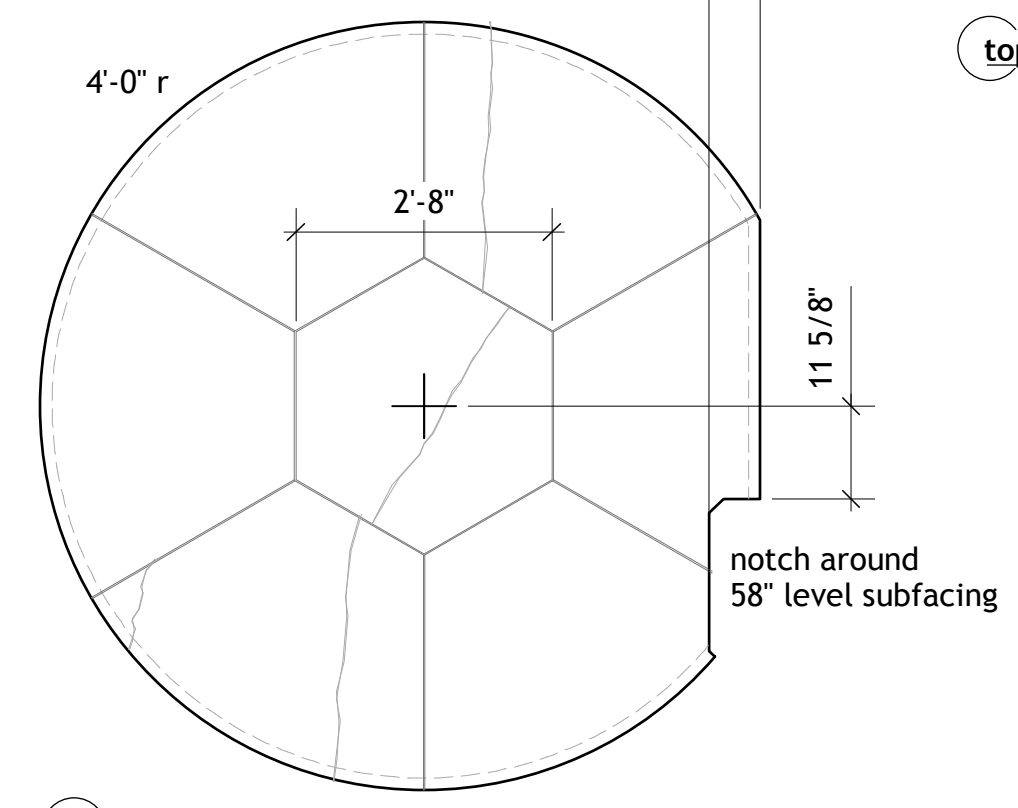

top view of 42" level

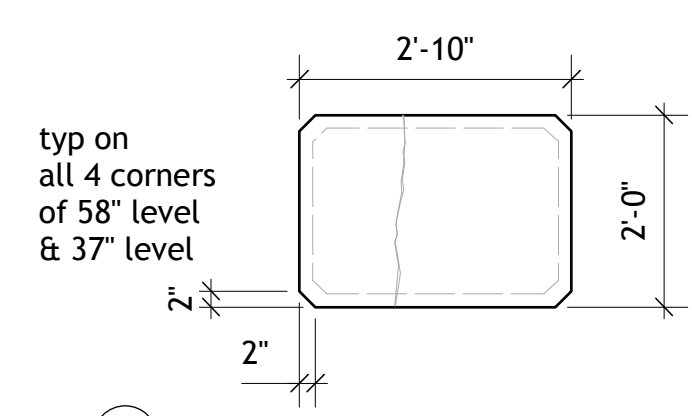

top view of 58" level

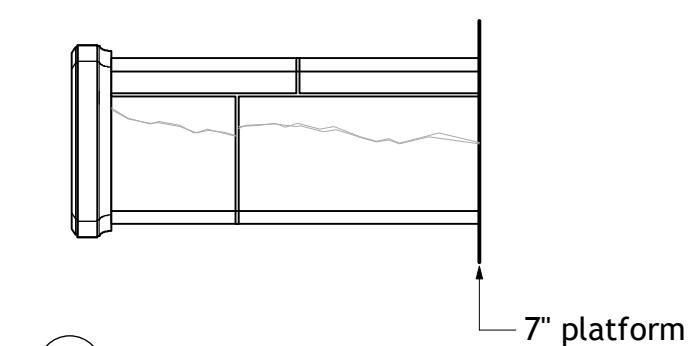

SL view of 58" level

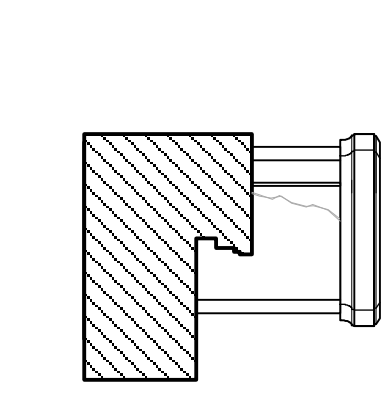

SR side view of 37" level

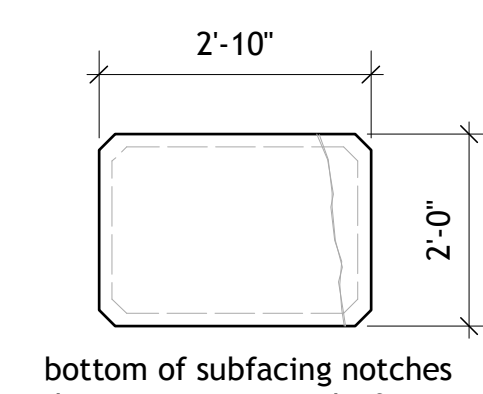

top view of 37" level

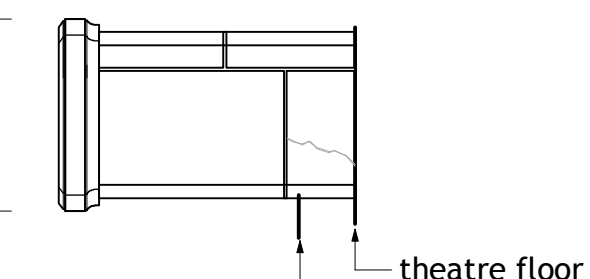

SL side view of 37" level

notes:
 tiles are based on a 2'-0" x 2'-0" x 1/4" sized stone (masonite?)
 subfacing is aged 2'-0" x 1'-0" x 1/4" stone (masonite?)
 (reduce each by 1/8" for sheet stock blade/ripping?)
 all subfacing is recessed 1 1/2", except on 37" & 58" levels
 those are inset 1 1/4"
 37" & 58" levels use the same facing as the bench (plate #9)
 are the cracks routed into the top skin?
 eric will distress some edges/corners prior to paint
 distress notes is a good starting place...
 discuss grout/seams on the facing will be seen/treated
 painted marble/stone finish on all surfaces

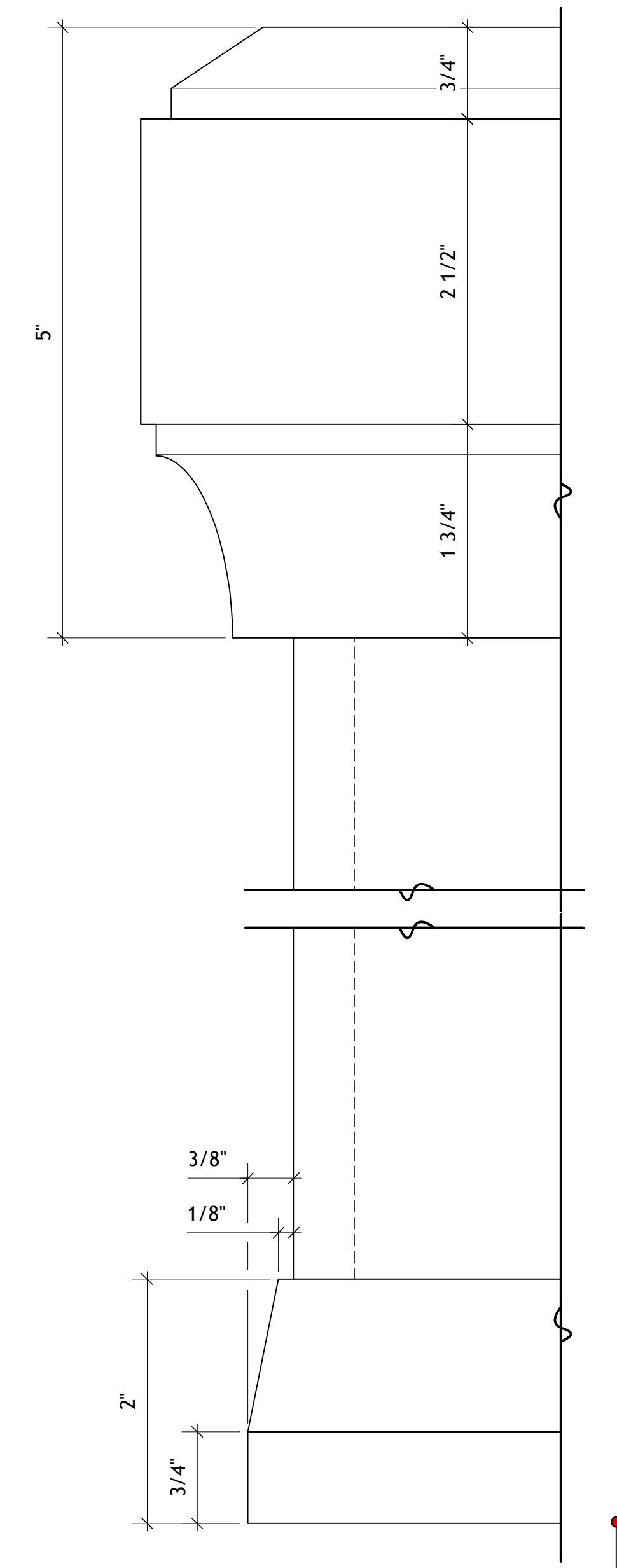
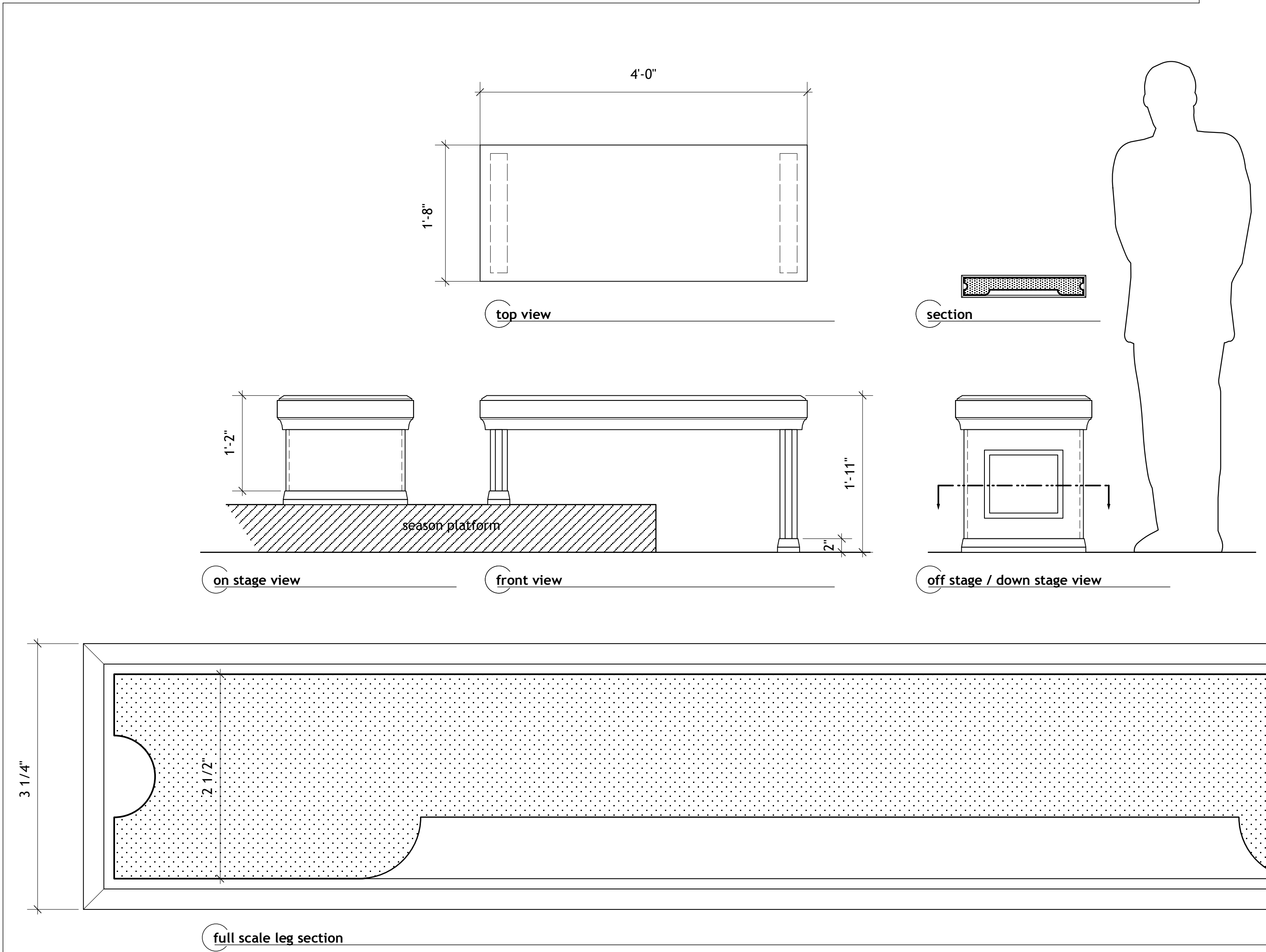
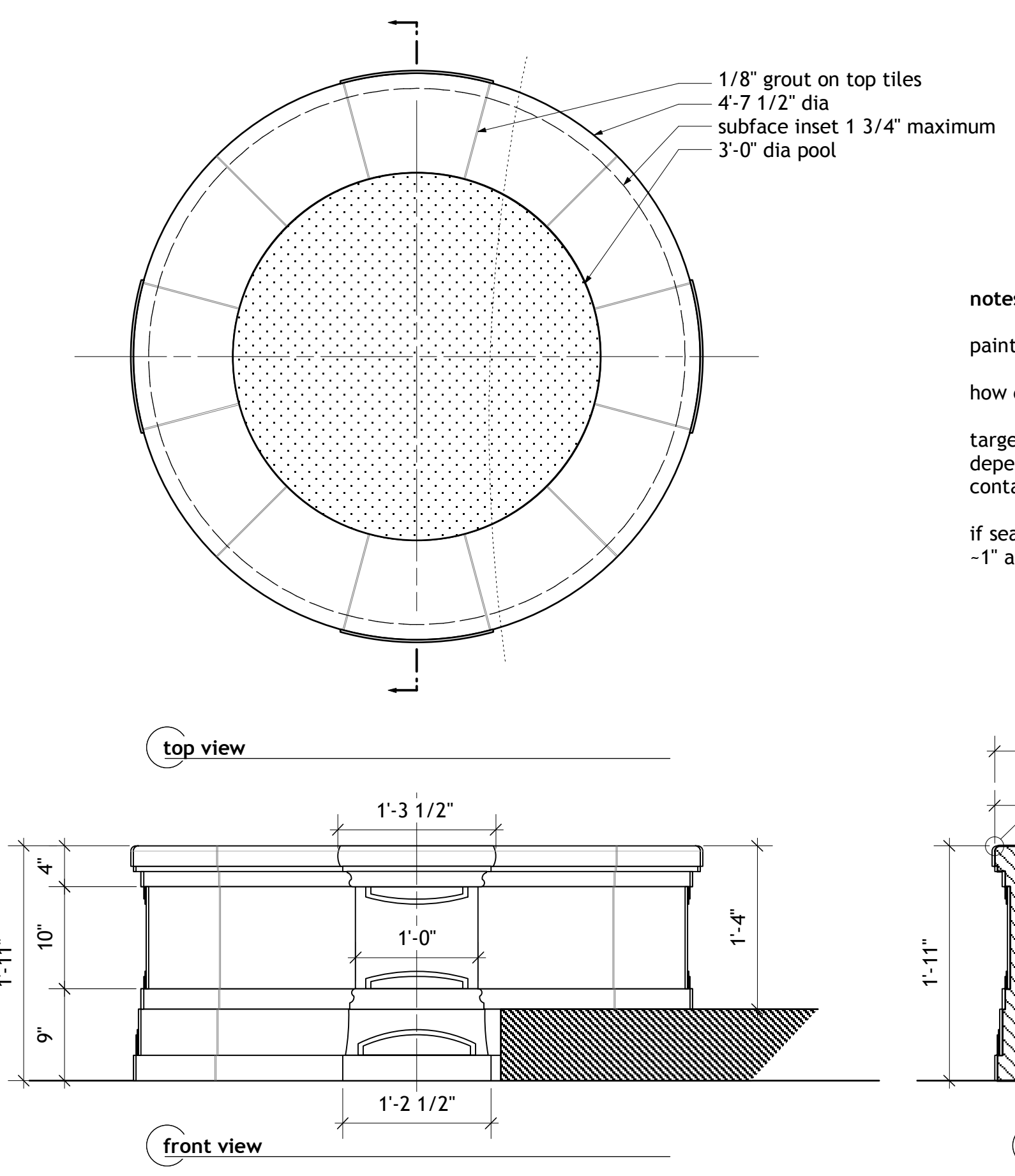
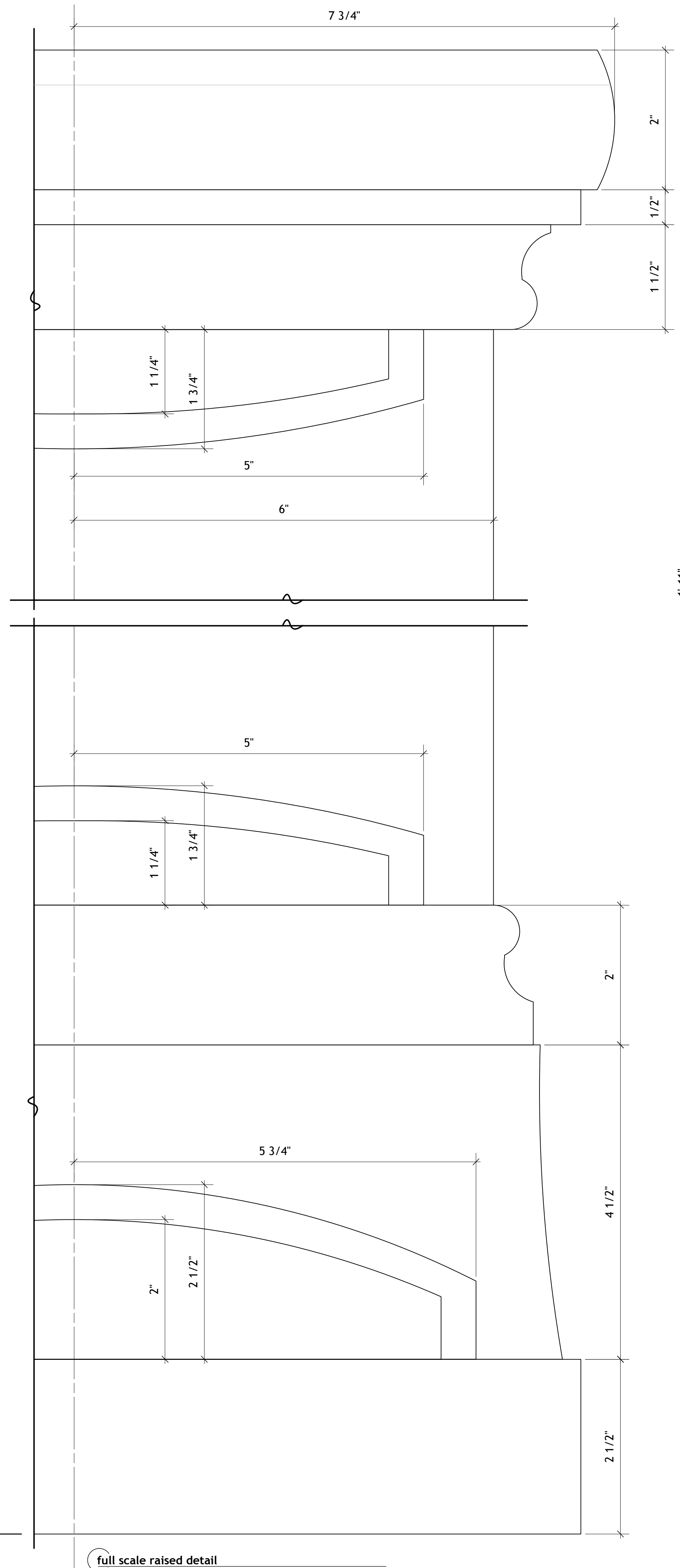
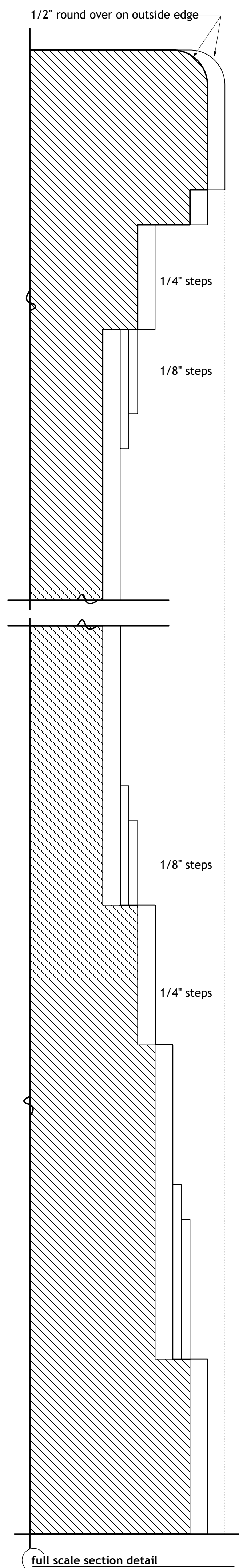

notes:

1/2" round over

1'-3 1/2"

1'-0"

1'-2 1/2"

1'-11"

10"

9"

1'-4"

4'-7 1/2"

9 3/4"

3'-0"

9 3/4"

1'-11"

water

full scale trim detail

notes:

1/2" round over

1'-3 1/2"

1'-0"

1'-2 1/2"

1'-11"

10"

9"

1'-4"

4'-7 1/2"

9 3/4"

3'-0"

9 3/4"

1'-11"

water

painting marble/stone finish on all surfaces

removable inside panel to access anchor down to deck?

is this the base trim?

confirm final position on plan w/ eric & paul in winona

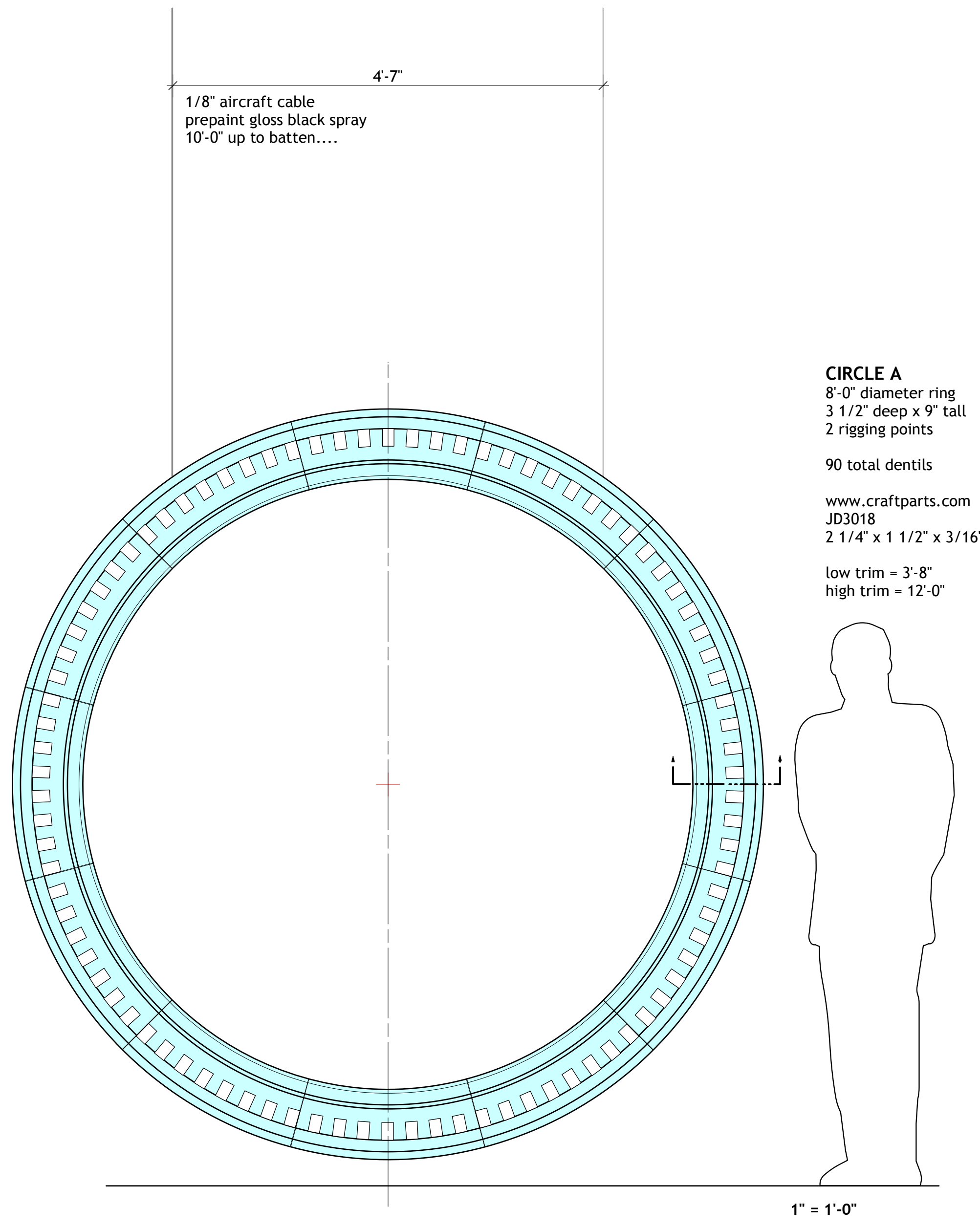
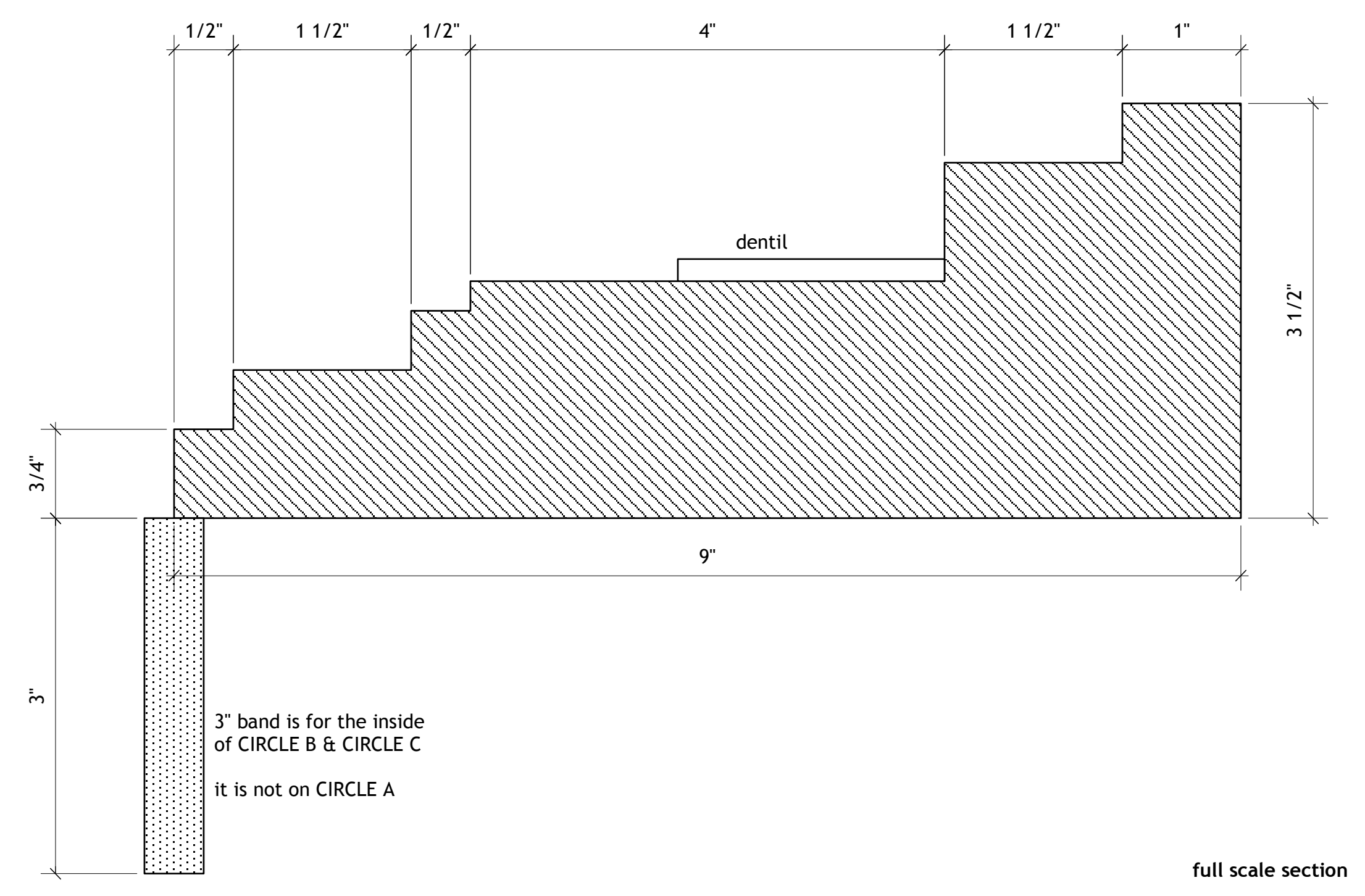
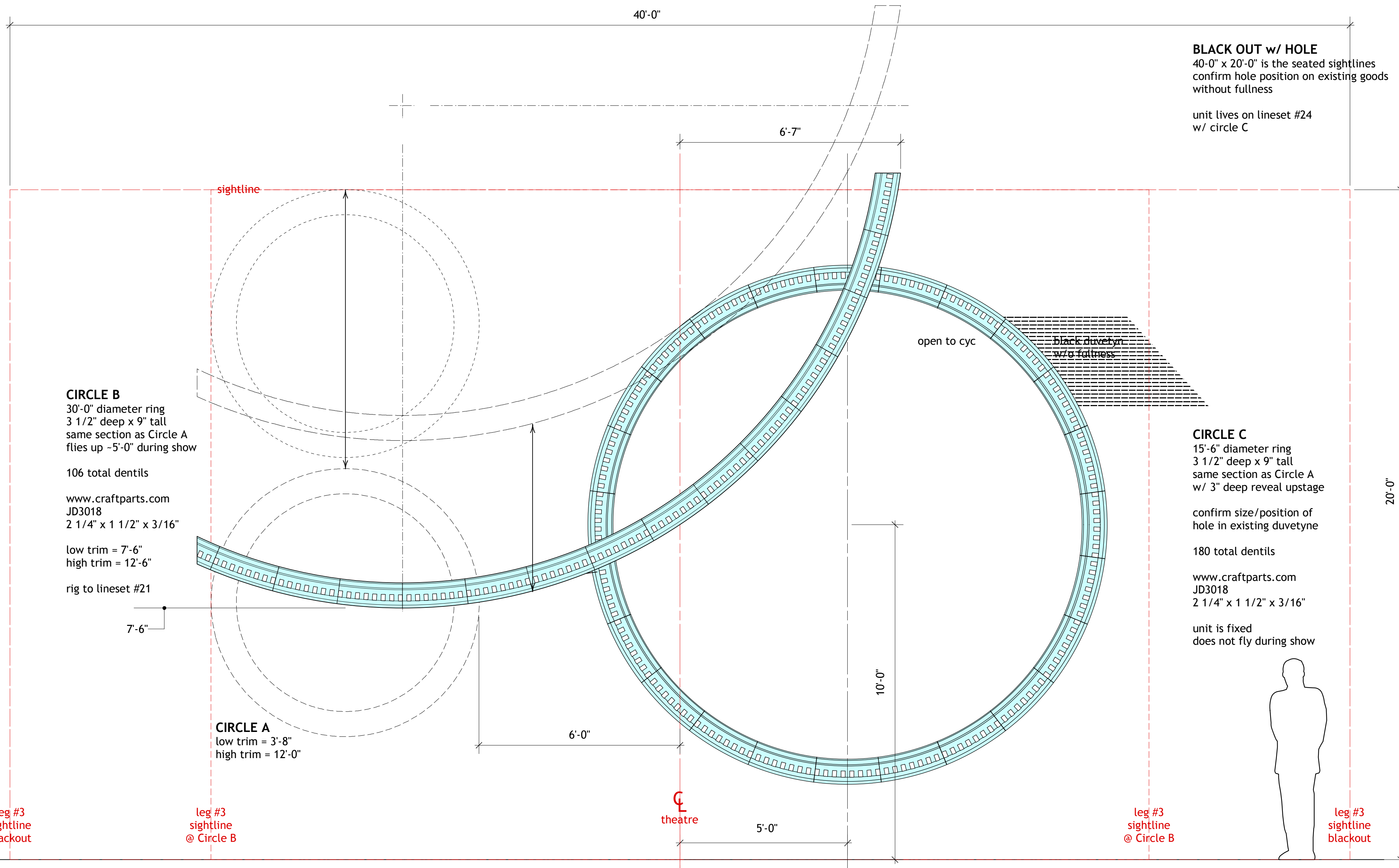

TREE SILHOUETTE
 flies in/out on lineset #26 for most Mantua scenes
 hard cutout
 1/4" thick?
 semi-gloss black finish

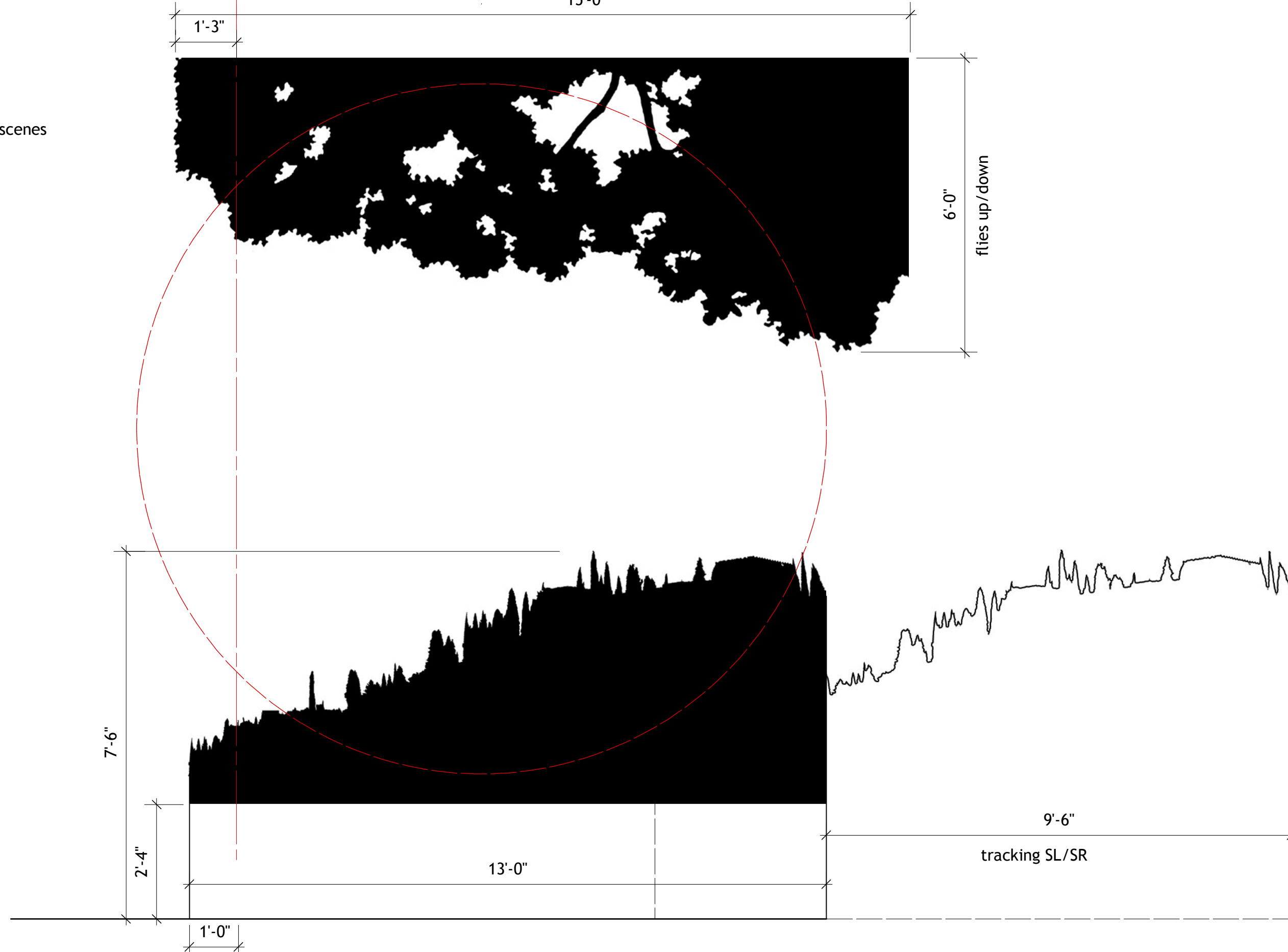

VERONA SILHOUETTE
 tracks SL/SR for most Verona scenes
 hard cutout
 top edge 1/4" thick?
 semi-gloss black finish

TWO GENTLEMEN OF VERONA great river shakespeare festival '12
 paul mason barnes, director | r. eric stone, scenic designer | tom korder, technical director

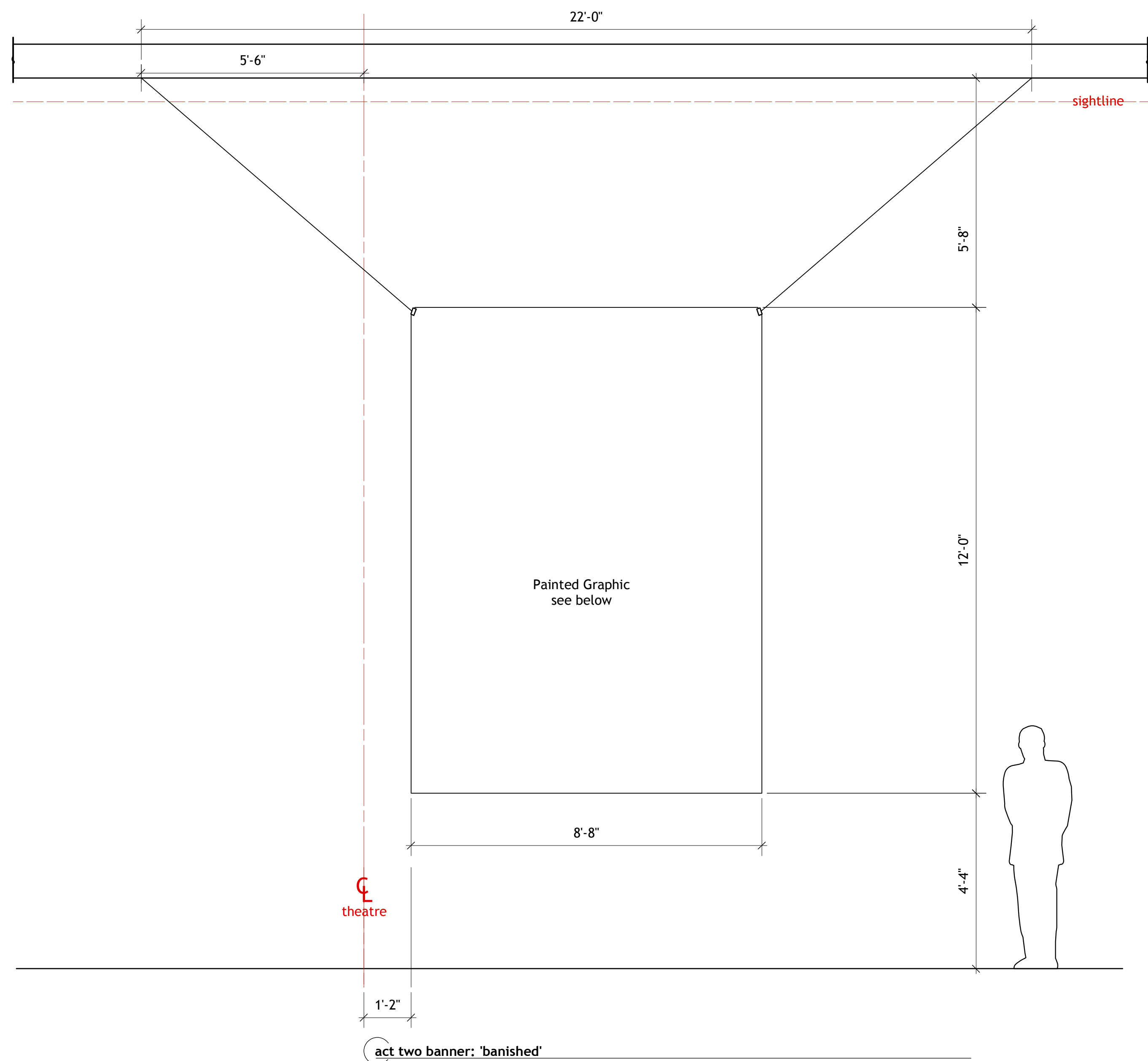

act two banner: 'banished'

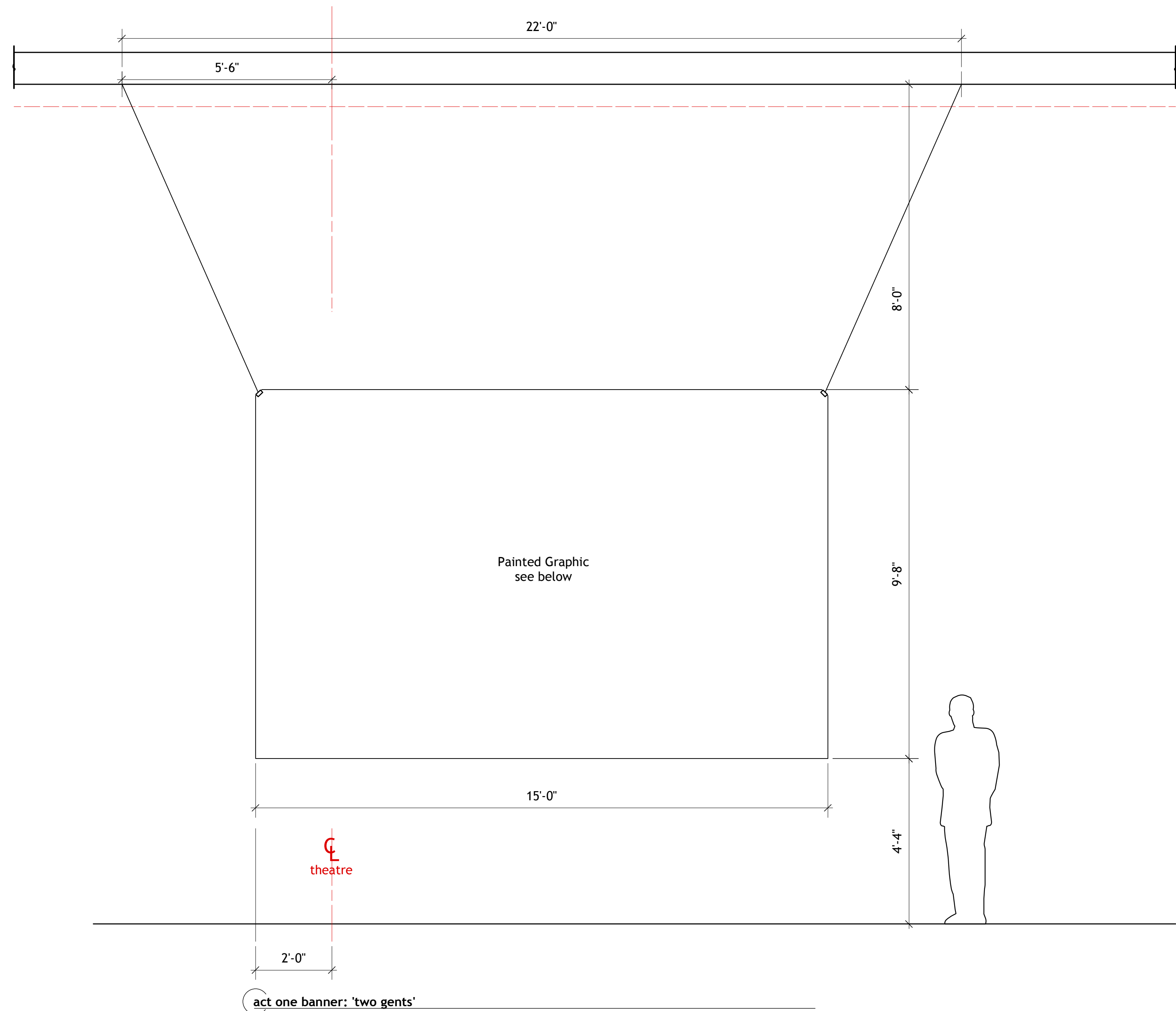

act one banner: 'two gents'

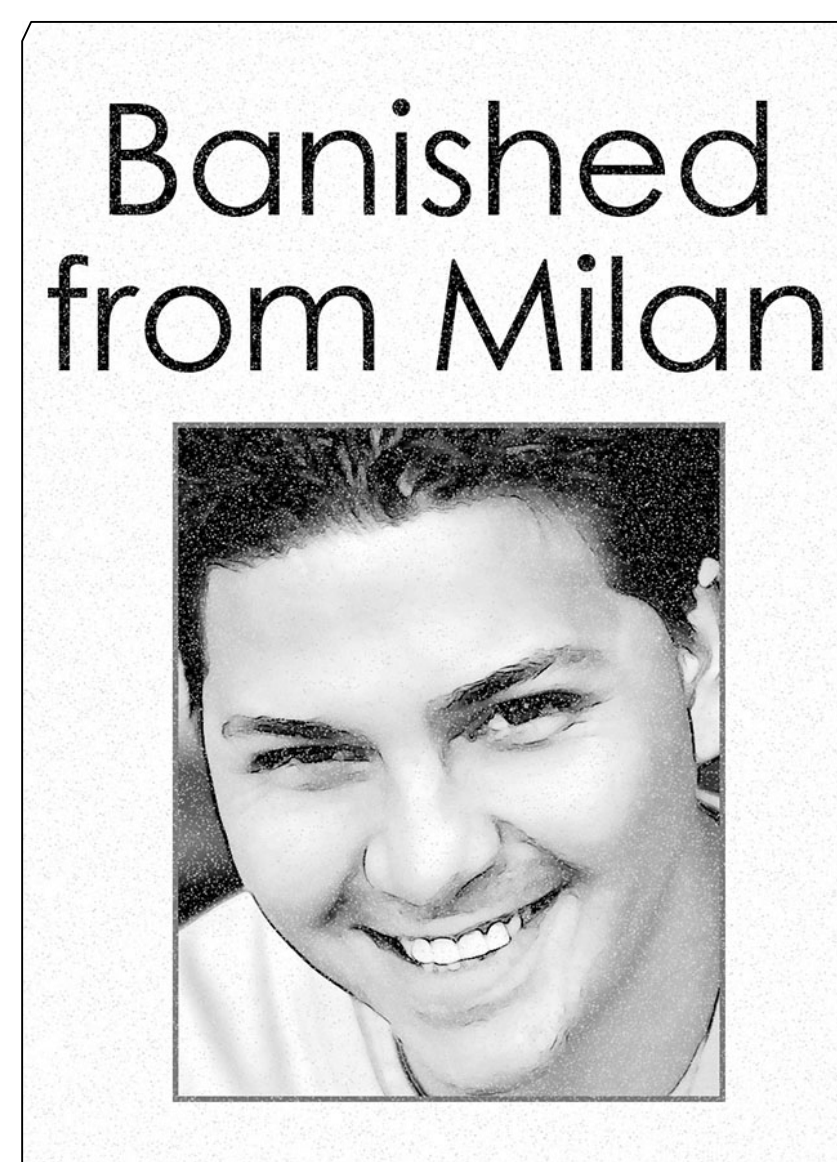

act two banner: 'banished' graphic layout



act one banner: 'two gents' graphic layout

'TWO GENTS' DROP
 light weight canvas drop
 discuss heam (2'?)
 preset/rigged to LEAR beam #1
 pulled down in scene
 ropes/clips fly up
 intermission rig is the same ropes for 'banished' drop

wall 7
hard skin
add jamb on US side of pass through door
to avoid light leak
back side of wall will be rigged with hooks & shelves
for prop/costume storage

wall 9 is connected to wall 1
acting as a jack for wall 1
wall 9 does NOT connect w/ wall 8
hard skin

wall 10 is connected to wall 6
acting as a jack for wall 6
wall 10 does NOT connect w/ wall 11
hard skin

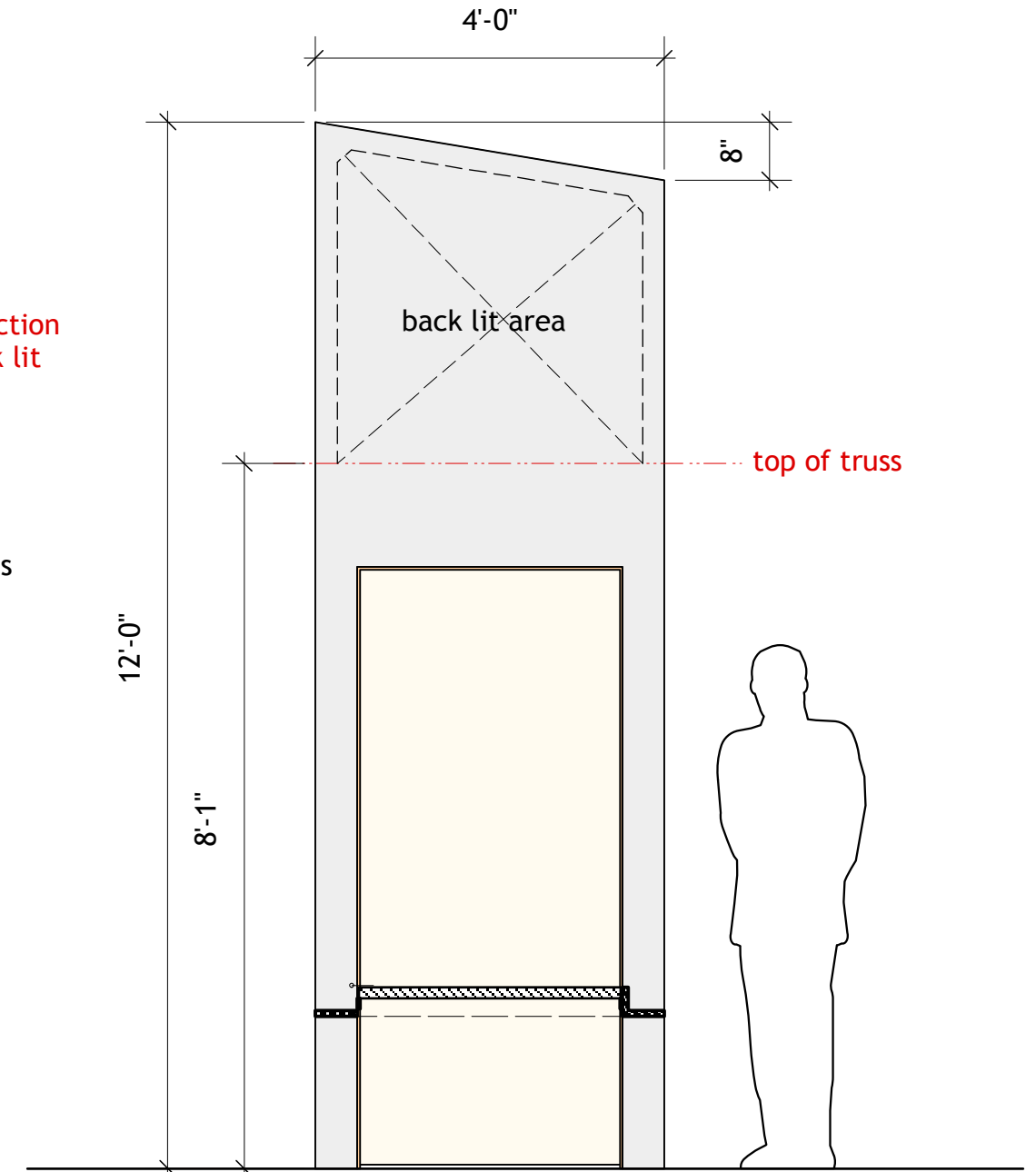
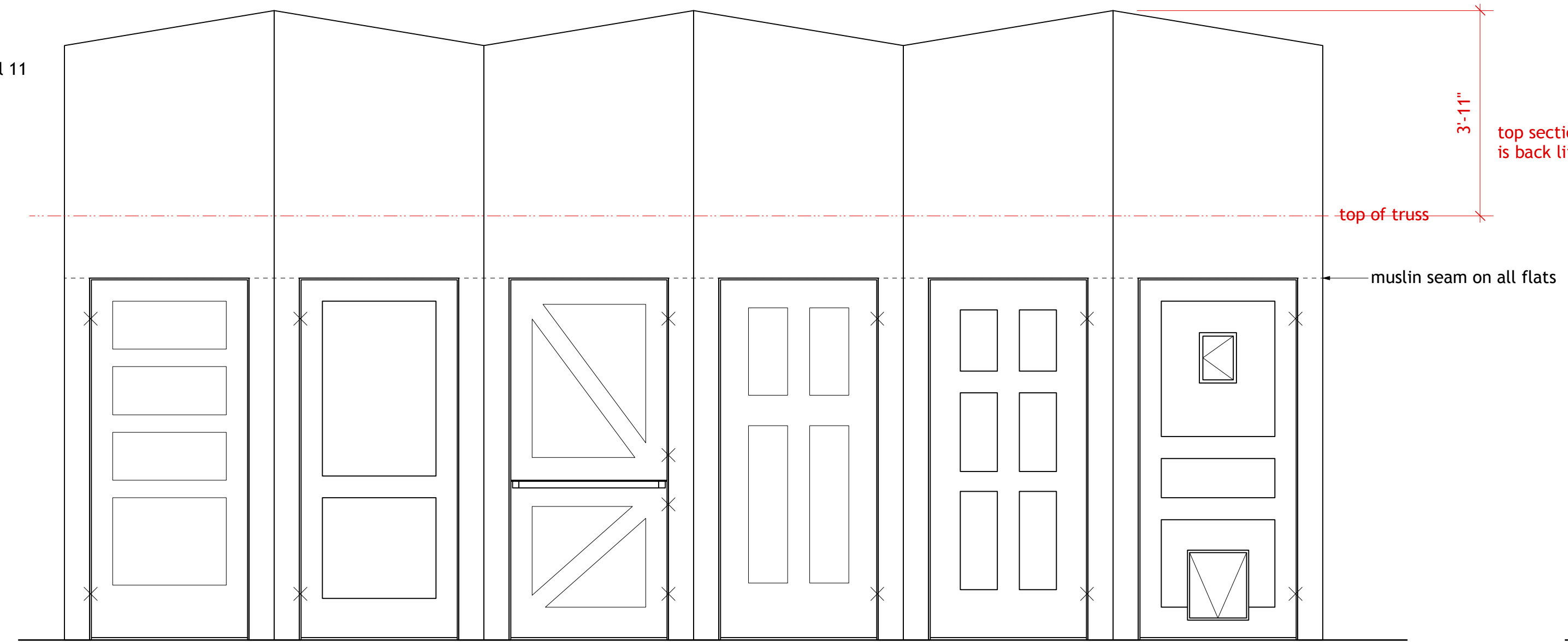
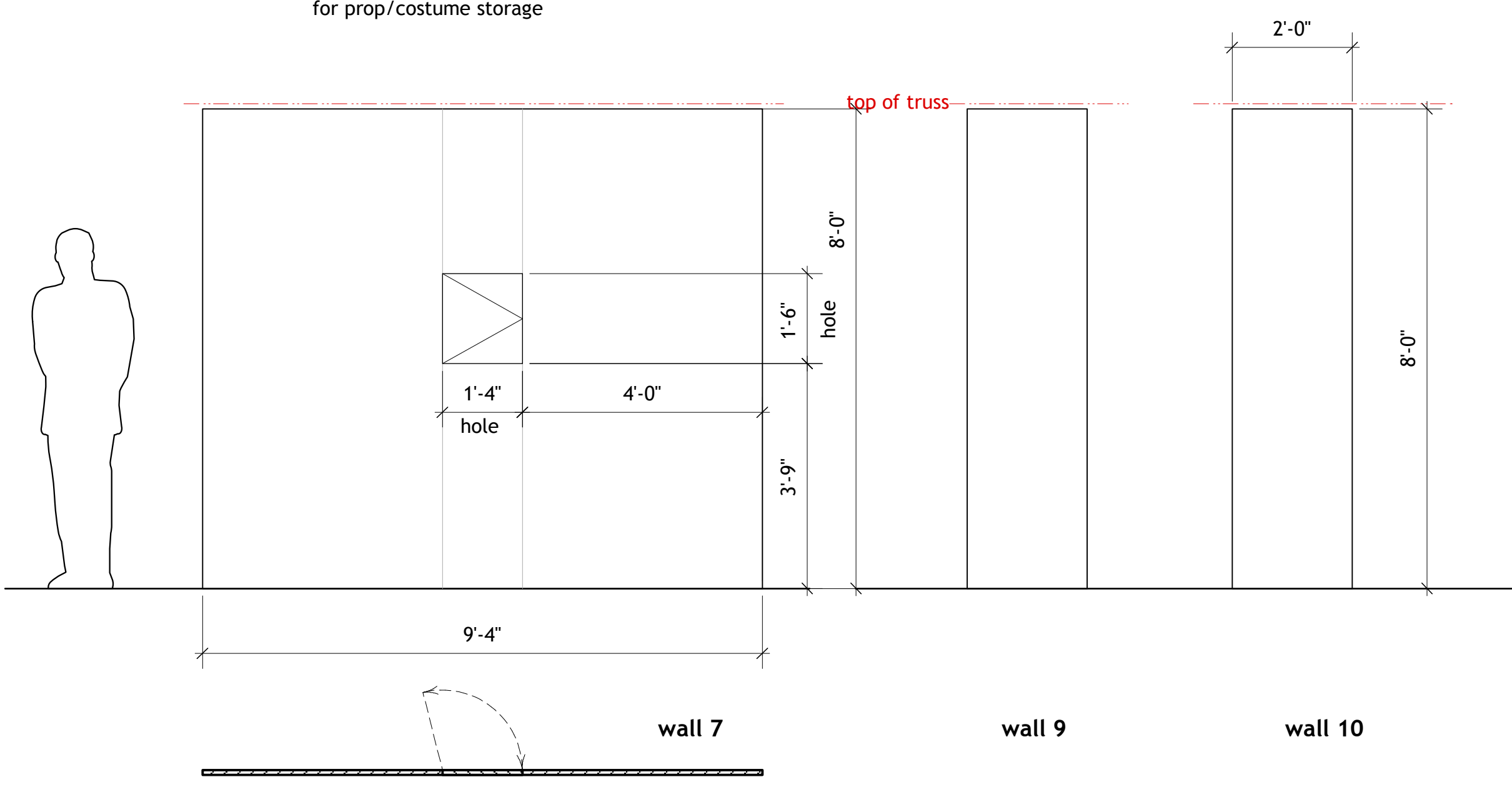

composite flat front view of walls 1 - 6

typical flat front view for each of walls 1 - 6

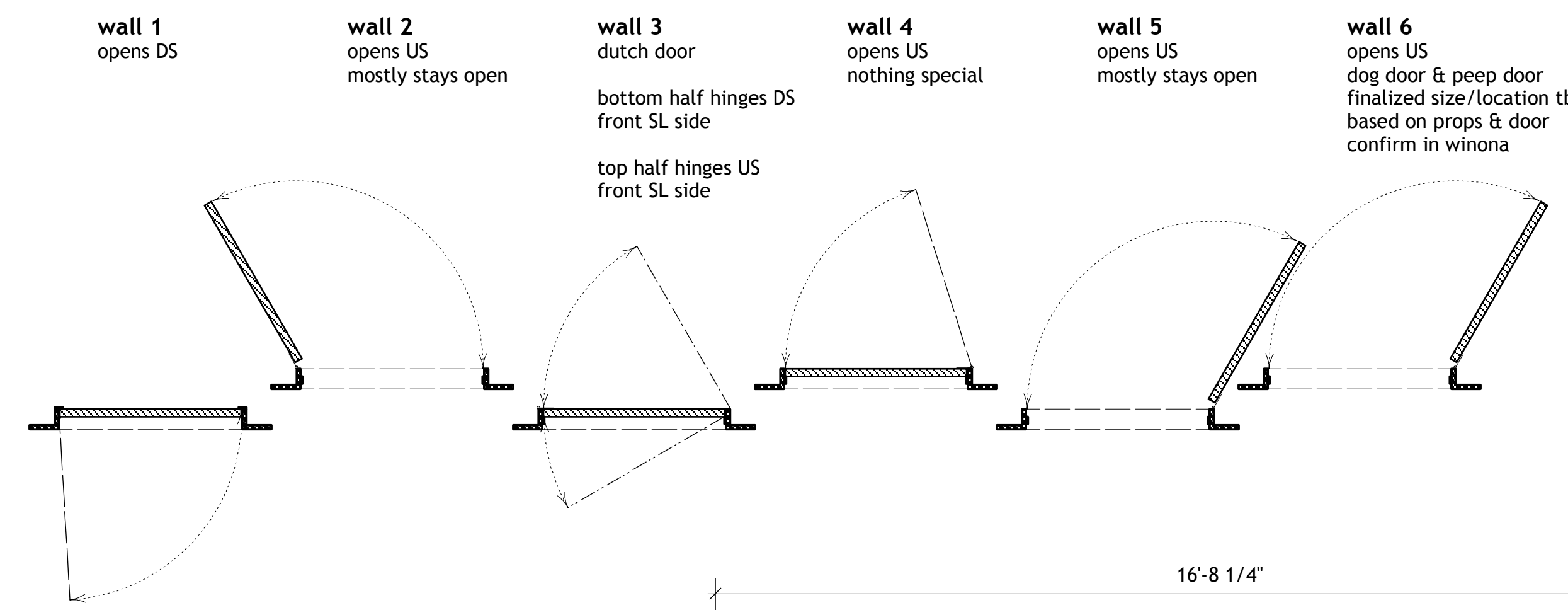

notes:

- typical door layout for 2, 4, 6
....R & R for 1, 3, 5
- pine & muslin construction...top/above doors are backlit
muslin cover entire wall (not doors)
- door drawings are representational...
ideally all are 36" wide
given that we are pulling the doors from stock,
getting them from 'restore'
or lowe's / home depot
- if possible, bevel the onstage edge of walls 3 & 4
so the joint is tight
- modify jamb as needed on bottom half of door 3
so the dutch door can swing DS
- adjust above framing as needed for structural logic. . .
- no door knobs or pulls on the DS side, handles on US side
confirm locking mechanisms needed on each door in winona

wall 8 & 11
hard skin
notch around season platform
paint finish is dark gray w/ graphic text
back side of wall may be rigged with hooks & shelves
for prop/costume storage

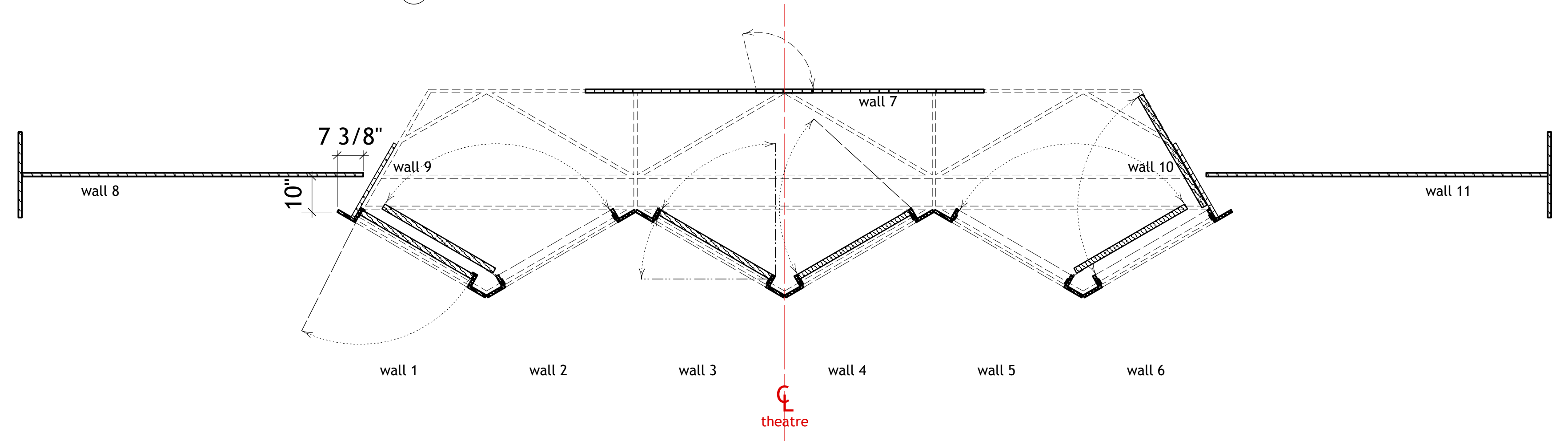
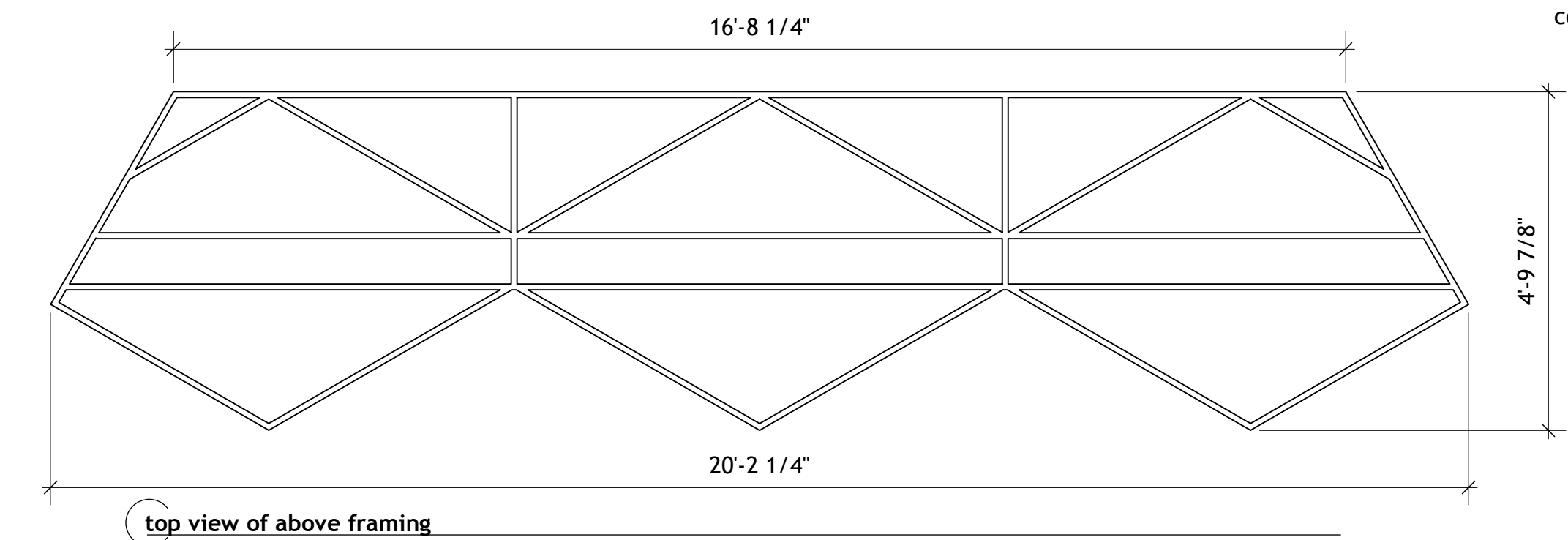
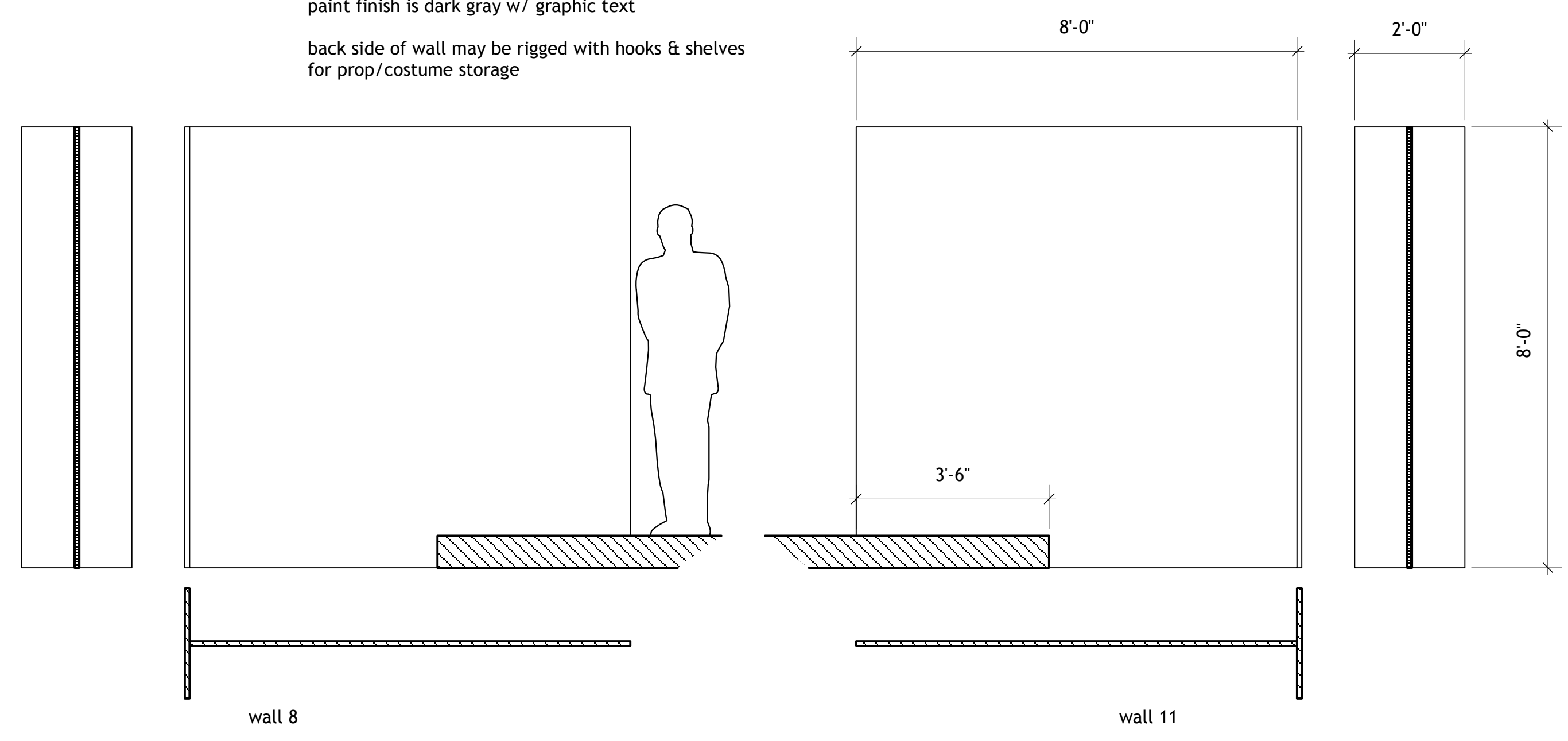

plan view of unit